

USER MANUAL A800

FCS4050

en

Original operating instructions • 20109324 • 02 • 2/22/2019



Read the user manual before working on the machine.

Keep the manual with the machine and pass the manual along to the next user if the machine is sold or transferred to a third party.

FRANKE

TABLE OF CONTENTS

1	For your safety.....	6
1.1	Intended use.....	6
1.2	Prerequisites for using the coffee machine	6
1.3	Explanation of safety instructions according to ANSI	7
1.4	General safety concerns when using the coffee machine and add-on units	8
2	Explanation of symbols	11
2.1	Symbols used in the manual.....	11
2.2	Symbols used in the software.....	11
3	Scope of delivery	14
4	Identification	16
4.1	Position of type plates	16
4.2	Type key	17
5	Description of machine	18
5.1	Coffee machine	18
5.2	Add-on units	21
5.3	Overview of operating modes	24
6	Installation.....	27
6.1	Preparations	27
6.2	Dimensions of the coffee machine with SU12 and other add-on units	27
6.3	Requirements of the water supply	29
7	Filling and emptying.....	31
7.1	Filling beans	31
7.2	Filling powder	32
7.3	Filling milk	32
7.4	Filling the Flavor Station.....	34
7.5	Setting the grind coarseness.....	35
7.6	Emptying the bean hopper	36
7.7	Emptying the powder hopper	36
7.8	Emptying the grounds container.....	37
7.9	Emptying the cooling unit.....	38
8	Preparing drinks.....	40
8.1	Dispensing drinks with Quick Select.....	40
8.2	Preparing drinks with Cash Register	40

8.3	Dispensing drinks with Inspire Me	41
8.4	Preparing a drink with ground coffee	41
8.5	Preparing hot water	42
8.6	Steam output.....	43
8.7	Steam dispenser (Autosteam/Autosteam Pro)	44
9	Cleaning	45
9.1	Introduction.....	45
9.2	5-step method.....	46
9.3	Required cleaning accessory.....	46
9.4	Starting the cleaning process.....	47
9.5	Rinsing coffee machine.....	48
9.6	Cleaning the aerator	49
9.7	Cleaning the Autosteam Pro/S3 components	49
9.8	Cleaning the screen.....	50
10	Configuration.....	51
10.1	Switching to the maintenance level	51
10.2	PIN codes.....	51
10.3	My settings menu tree	52
10.4	Input methods	52
10.5	Menu 0 Commissioning	52
10.6	Menu 1 Set machine.....	52
10.7	Menu 3 Date and time	59
10.8	Menu 4 Nutritional value information.....	60
10.9	Menu 6 Access rights	62
11	Individualization and data transfer	64
11.1	Overview	64
11.2	Individualization and data transfer menu tree	65
11.3	Switching to the maintenance level	66
11.4	Requirements for your own media	66
11.5	Loading or deleting your own media	67
11.6	Using your own advertising media	67
11.7	Displaying languages and configuring nutritional values	68
11.8	Loading/backing up data.....	68
11.9	Restoring default values.....	69
12	Troubleshooting.....	70

12.1	Error messages.....	70
12.2	Tips for good coffee drinks.....	71
12.3	Help with problems concerning product quality	72
13	Decommissioning	73
13.1	Preparing for decommissioning	73
13.2	Short-term decommissioning (up to 3 weeks).....	73
13.3	Long-term decommissioning	73
13.4	Transport and storage.....	74
13.5	Recommissioning after prolonged periods of storage or non-use	74
14	Disposal of parts.....	75
15	Technical data	76
15.1	Capacities in accordance with DIN 18873-2:2016-02	76
15.2	Technical data of the coffee machine	76
15.3	Coffee machine electrical connections.....	76
15.4	Power cord	77
	Index.....	78

1 FOR YOUR SAFETY

1.1 Intended use

1.1.1 Coffee machine

- The A800 is a commercial machine for preparing drinks and is intended for use in food services, offices and other similar environments.
- The A800 is designed to process whole coffee beans, ground coffee, powder that is suitable for automatic devices, and fresh milk.
- The A800 is intended for the preparation of drinks in accordance with these instructions and the technical data.
- The A800 is intended for operation indoors.

Please note

- The A800 is not suitable for use outdoors.

1.1.2 Add-on units

Cooling unit

- The cooling unit is used exclusively to keep milk cool while preparing coffee drinks with a coffee machine. Only use pre-cooled milk (2–5 °C).
- Only use Franke milk system cleaning agent.

Please note

- Other cleaning agents may leave residue in the milk system.

Cup warmer

- The cup warmer is intended only for preheating coffee cups and glasses used when preparing drinks.

Please note

- The cup warmer is not designed to dry dish towels or other cloths. It is not necessary to cover the cups to warm them.

Flavor Station

- The Flavor Station is intended exclusively for the automatic conveyance of syrups and other fluid aromas for the preparation of drinks.

Please note

- The Flavor Station is not designed to pump viscous fluids such as chocolate sauce.
- The Flavor Station is not suitable for the storage of alcoholic or explosive substances.

Accounting system

- Depending on the version, the accounting system can be used for various methods of payment. Examples: Payment with coins, cards, or mobile payment systems.

1.2 Prerequisites for using the coffee machine

- The A800 is intended for use by trained personnel.
- Each operator of the A800 must have read and understood the manual. This does not apply to its use in the self-service sector.
- Self-service machines must always be monitored to protect the users.

- Do not operate the A800 or add-on units until you have completely read and understood this manual.
- Do not use the A800 or add-on units if you are not familiar with the various functions.
- Do not use the A800 if the connection lines of the A800 or the add-on units are damaged.
- Do not use the A800 unless the A800 or the add-on units have been cleaned or filled as intended.
- Children under the age of 8 are not permitted to use the A800 and the add-on units.
- Children or persons with reduced physical, sensory, or mental capabilities must not use the A800 and the add-on units except under supervision, nor should they be permitted to play with the A800 and the add-on units.
- Children are not permitted to clean the A800 and the add-on units.

1.3 Explanation of safety instructions according to ANSI

Observation of these safety instructions is imperative to ensure personal safety and the protection of material goods.

Symbol and signal word indicate the severity of the hazard.



WARNING

WARNING indicates a potential danger. **DANGER** indicates an imminent danger which, if not avoided, will result in death or serious injury.



CAUTION

CAUTION indicates a hazardous situation which, if not avoided, could result in minor or moderate injury.



NOTICE

NOTICE directs your attention to the risk of damage to machinery.

1.4 General safety concerns when using the coffee machine and add-on units



WARNING

Risk of fatal injury from electrocution

Damaged power cords, lines or plug connections can lead to electrocution.

- a) Do not connect any damaged power cords, lines or plug connections to the power supply.
- b) Replace damaged power cables, lines or plug connections.
If the power cord is permanently attached, contact the service technician. If the power cord is not permanently attached, order and use a new, original power cord.
- c) Ensure that the machine and the power cord are not near any hot surfaces such as gas or electric stoves or ovens.
- d) Ensure that the power cord is not pinched and does not chafe on sharp edges.



WARNING

Risk of fatal injury from electrocution

Liquid/moisture entering the machine or leaks can lead to electrocution.

- a) Never point a liquid or steam jet at the machine.
- b) Do not pour any liquids on the machine.
- c) Do not immerse the machine in liquid.
- d) Disconnect the machine from the power supply in the event of a leak or if liquid/moisture enters the machine.



WARNING

Risk of fatal injury from electrocution

Work, repairs or servicing improperly performed on electrical systems can lead to electrocution.

- a) Have repairs on electrical parts carried out by service technicians using original spare parts.
- b) Have servicing carried out by authorized persons with corresponding qualification only.



WARNING

Danger of suffocation

Plastic packaging materials could cause children to suffocate.

- a) Ensure that children have no access to plastic packaging materials.

**⚠ WARNING****Risk of burns**

The heating surfaces of the cup warmer can cause burns or a fire.

- a) Do not touch the hot heating surfaces of the cup warmer.
- b) IN CASE OF BURNS: Immediately cool the affected area and consult a doctor depending on the severity of the injury.
- c) Do not place anything flammable on the cup warmer.

**⚠ WARNING****Risk of scalding**

Hot water is released during rinsing.

- a) Keep hands away from the spouts and nozzles during this process.
- b) Do not place anything on the drip grid.
- c) IN CASE OF SCALDING: Immediately cool the affected area and, depending on the severity of the injury, consult a doctor.

**⚠ WARNING****Risk of scalding**

Hot drinks can lead to scalding.

- a) Always be careful with hot drinks.
- b) Use only suitable drinking vessels.

**⚠ WARNING****Risk of scalding**

Hot liquids and steam escape during cleaning and can lead to scalding.

- a) Keep hands away from the spouts and nozzles during this process.

**⚠ WARNING****Risk of injury**

If objects find their way into the bean hopper or grinder, splinters may be ejected, leading to injury.

- a) Never insert any objects into the bean hopper or grinder.

**⚠ CAUTION****Cutting injuries/crushing**

The powder hopper's feeding mechanism can cause cuts or crushing injuries.

- a) Exercise care when cleaning the powder hopper.

**⚠ CAUTION****Irritation from cleaners**

Cleaning tablets, milk system cleaning agent, and descaler can lead to irritations.

- a) Observe the hazard warnings on the label of the respective cleaner.
- b) Avoid contact with your eyes and skin.
- c) Wash your hands after coming into contact with cleaner.
- d) Cleaners must not find their way into drinks.

**⚠ CAUTION****Health hazard due to germ formation**

Inadequate cleaning can result in food residues accumulating in the machine and at the outlets, thereby contaminating products.

- a) Do not use the machine unless it has been cleaned according to the instructions.
- b) Clean the machine daily in accordance with the instructions.
- c) Inform operating personnel of the necessary cleaning measures.

**⚠ CAUTION****Health hazard due to germ formation**

If the machine is not used for extended periods, residue may accumulate.

- a) Clean the machine if it is not used for extended periods (more than 2 days).

**⚠ CAUTION****Health hazard due to algae formation**

Using a water filter for too long can lead to the build-up of algae.

- a) Replace the water filter when prompted to do so by the machine.

**⚠ CAUTION****Formation of mold**





Mold can form on the coffee grounds.

- a) Empty and clean the grounds container at least once a day.

2 EXPLANATION OF SYMBOLS



2.1 Symbols used in the manual

2.1.1 Orientation

Symbol	Description
	Clean components using the 5-step method.
	This symbol indicates tips, tricks and additional information
	Prerequisites for additional steps
	Result or intermediate result for additional steps

2.2 Symbols used in the software





2.2.1 Symbols used for navigation and operation



















Symbol	Designation	Description
	Cancel button	Cancel preparation
	Select next/previous page	Scroll through menus with multiple pages
	Start button	Start preparation





2.2.2 Symbols on the dashboard



When a symbol is illuminated on the dashboard, additional information and instructions can be displayed by tapping the symbol. Refer to the "*Troubleshooting* [▶ 70]" chapter for help if an error occurs.

Symbol	Designation	Description
	Franke logo	Call up the maintenance level
	Servicing/cleaning	Machine must be cleaned and/or serviced
	Coffee bean	Bean hopper is empty or not installed correctly
	Grounds container	Grounds container must be emptied

Symbol	Designation	Description
	Rinse	Machine must be rinsed or machine rinses
	Product	
	Payment	Payment active
	Advertising images	
	Screen saver	
	Brightness	Set brightness
	Data transfer	Data being transferred
	Individual products counter	
	Individualization	
	Info	
	Inactive	
	Standby	Switch the machine to standby
	First Shot	Preheat system
	Door	The door is open.
	Favorites	Favorites button, can be assigned to a function that is used frequently
	Service/configuration/administration	
	Bean left/right	Active grinder
	Double product	Prepare double drink quantity (double dispensing)

Symbol	Designation	Description
	Ground coffee	
	Hot chocolate	
	Cold milk	
	Milk	Milk container is empty or not installed correctly
	Milk system cleaning agent	Milk system cleaning agent is empty (CleanMaster)

2.2.3 Depiction of error messages





Highlighted products cannot be prepared. The illuminated symbol on the dashboard takes you to the error message.

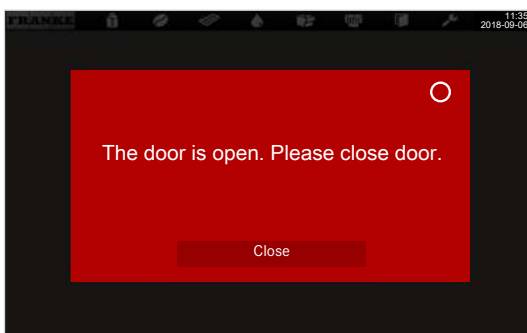

If the entire system is affected by an error, the error message will appear automatically.



Color code for error messages









-  Temporary interruption
-  System still fully functional
-  System has limited functionality
-  Some or all resources are locked

3 SCOPE OF DELIVERY



The scope of delivery may vary, depending on the device configuration. Additional accessories may be obtained directly from your retailer or from Franke Kaffeemaschinen AG in Aarburg, Switzerland.

	Item description	Item number
	Cleaning tablets (100 pcs.)	567.0000.010
	Cleaning tablets (China)	567.0000.016
	Cleaning tablets (USA/Canada)	567.0000.002
	Milk system cleaning agent (dosing bottle)	567.0000.005
	Milk system cleaning agent (dosing bottle) (USA/Canada)	567.0000.003
	Cleaning brushes	560.0003.728
	Twisted-in-wire brush (Option SU05)	560.0001.019
	Hose brush (option FM/MS)	560.0007.380

	Item description	Item number
	Cleaning brush	560.0003.716
	Microfiber cloth	560.0002.315
	Grinder adjustment wrench	560.0003.876
	Aerator / hose wrench	560.0522.696
	USB stick (4 GB)	560.0003.285
	Measuring cup	560.0002.653
	Drip grid plate	560.0484.609
	Manual set	560.0001.662

4 IDENTIFICATION

4.1 Position of type plates

4.1.1 Coffee machine



The type plate for the coffee machine is located on the right interior wall next to the grounds container.

4.1.2 SU12

The type plate for the SU12 is located in the cooling chamber.

4.1.3 SU05



The type plate of the SU05 is located on the inner side of the door.

4.1.4 FS3/FS6

The type plate for the Flavor Station is located in the interior.

4.1.5 CW

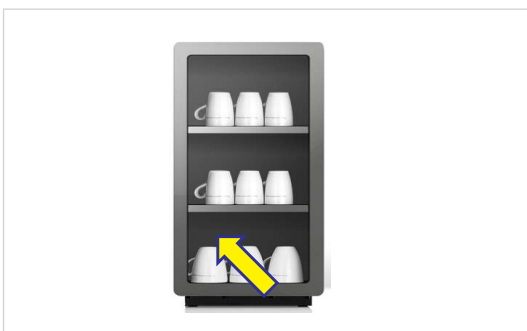

The type plate for the cup warmer is located on the inner side of the rear panel in the left-hand bottom corner.

4.2 Type key

4.2.1 Coffee machine

Code	Description
A800	Coffee machine (fully automatic device) Series: A Overall size: 800
1G	1 grinder
2G	2 grinders
3G	3 grinders
1P	1 powder hopper
2P	2 powder hoppers
EC	EasyClean
FM	FoamMaster (cold and hot milk, cold and hot milk foam)
H1	Hot water dispenser
S1	Steam wand
S2	Autosteam (steam wand with temperature sensor)
S3	Autosteam Pro (steam wand with temperature sensor and programmable milk foam texture)

4.2.2 Add-on units

Code	Description
1C1M	1 coffee machine, 1 milk type
1C2M	1 coffee machine, 2 milk types
2C1M	2 coffee machines, 1 milk type
2C2M	2 coffee machines, 2 milk types
AC	Accounting unit
CW	Cup warmer
EC	EasyClean
FM	FoamMaster (cold and hot milk, cold and hot milk foam)
FS3	Flavor Station with 3 syrup pumps
NM	Machine without milk system (NoMilk)
SU05 EC	Cooling unit (< 10 l) with EasyClean cleaning
SU12 CM	Cooling unit (≥ 10 l) with CleanMaster cleaning
SU12 EC	Cooling unit (≥ 10 l) with EasyClean cleaning
UC05	Base cooling unit (< 10 l)
UT12 EC	Under-counter cooling unit (≥ 10 l) with EasyClean cleaning

5 DESCRIPTION OF MACHINE

5.1 Coffee machine

Introduction

The A800 coffee machine is available with numerous options. To provide you with an overview of your machine, a sample configuration is illustrated here. Please note that your coffee machine may look different from the configuration shown here.



5.1.1 Standard

- One grinder (rear LH)
- Hot water spout
- Spout with automatic height setting
- Water connection

5.1.2 Options

- iQFlow
- Second grinder (rear RH)
- Third grinder
- Powder hopper (RH)
- Second powder hopper (LH)
- Steam wand

- Autosteam function for automatically heating milk
- Autosteam Pro function for foaming/frothing milk automatically
- Two milk types
- Coffee ground chute
- Spout for jug
- Lockable bean and powder hopper
- High adjustable feet (*Adjustable feet* [▶ 29](#))
- Cup sensor
- External water tank
- First Shot
- M2M/telemetry preparation

5.1.3 Coffee machine components

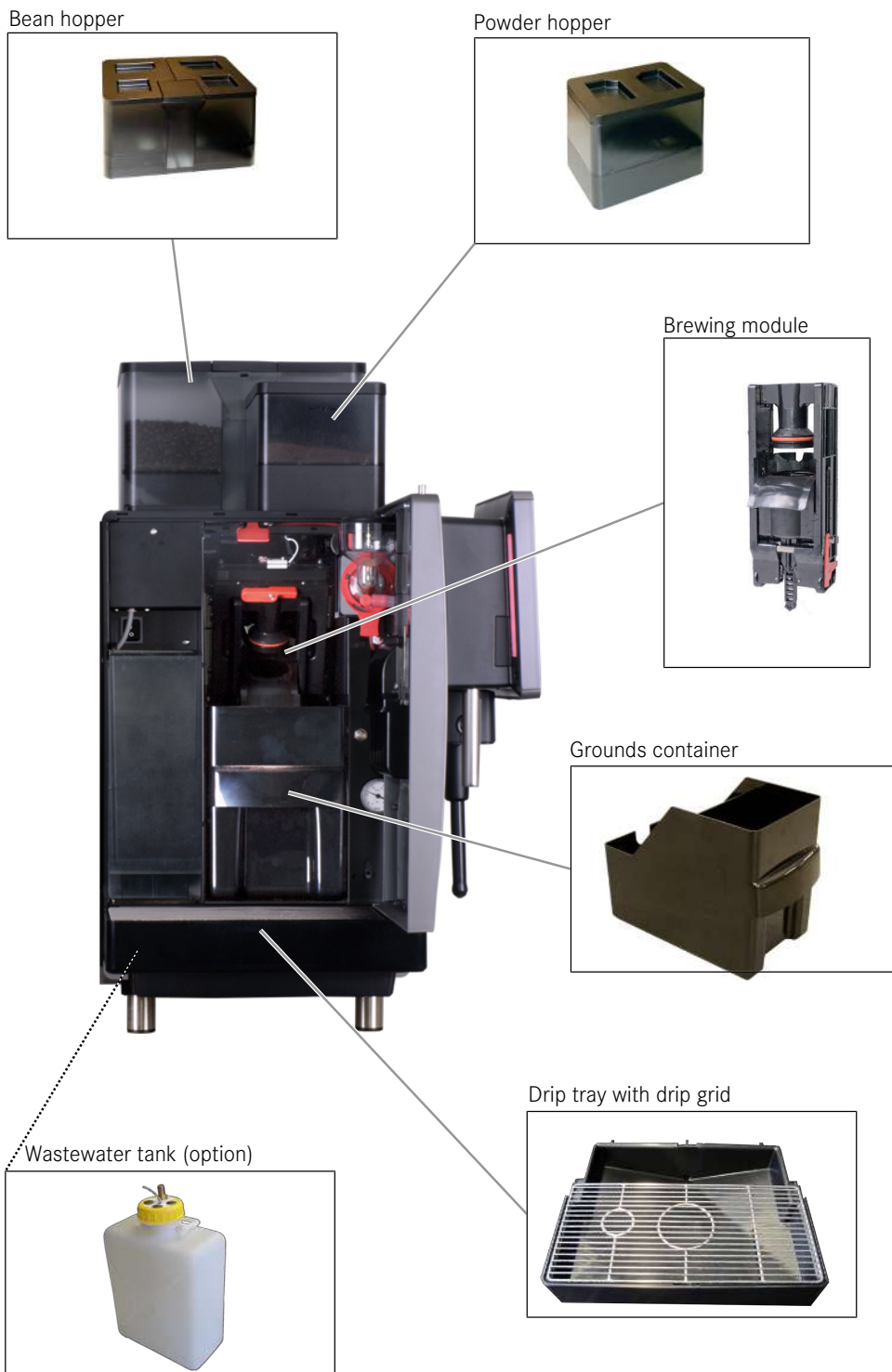

5.2 Add-on units

5.2.1 Components of the cooling unit with EasyClean

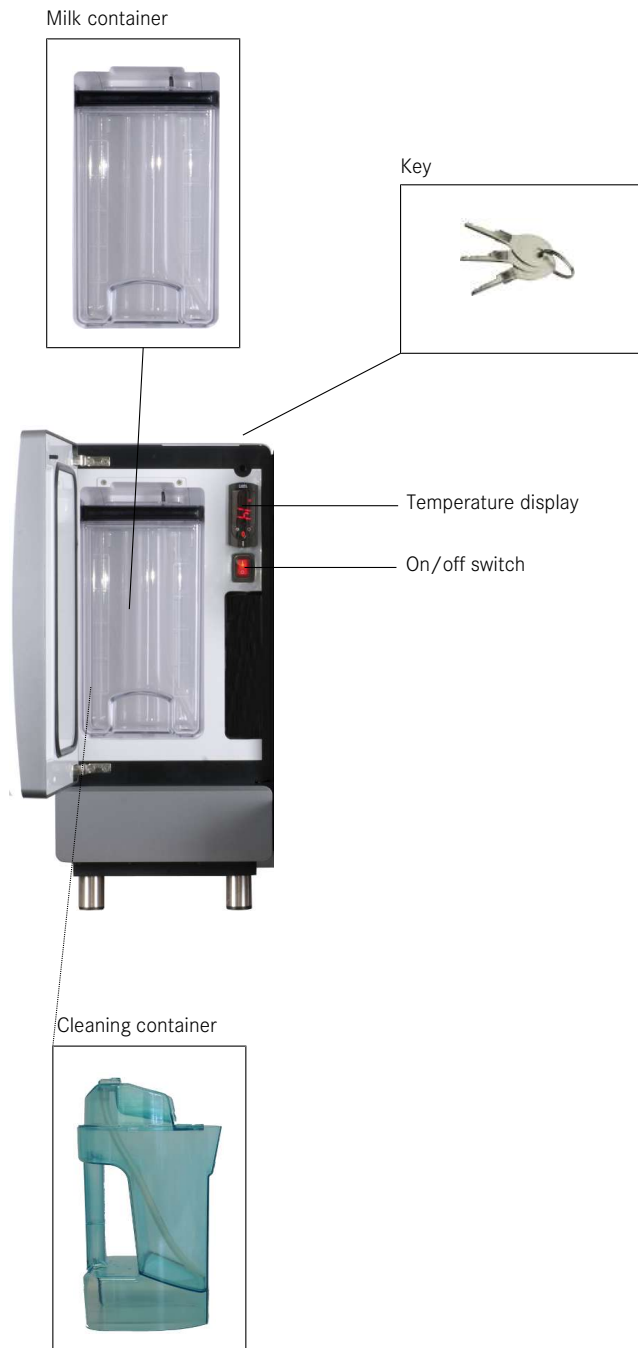

5.2.2 Cooling unit SU12 FM EC

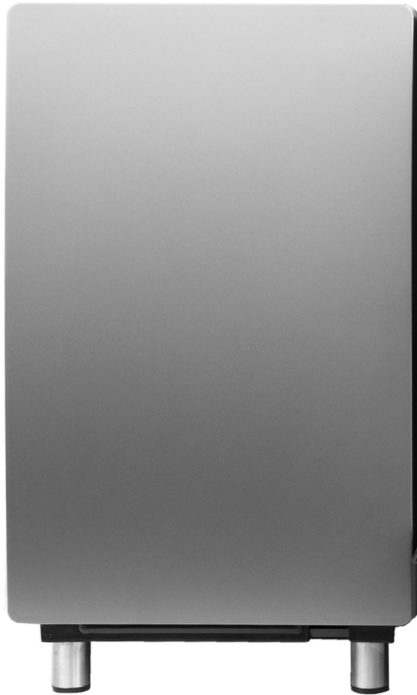

- Automatic cleaning system
- Connection to the left-hand and right-hand of the machine possible
- Lockable

Versions

- SU12 with 12 l milk container
- SU12 with 2 x 4.5 l milk containers for the use of 2 milk types
- SU12 Twin with 2 x 4.5 l milk containers for connecting 2 coffee machines
- UT12 FM under-counter cooling unit with 12 l milk container
- UT12 FM Twin under-counter cooling unit with 2 x 4.5 l milk containers for connecting 2 coffee machines
- MU (assembly under the counter)

5.2.3 Flavor Station FS3

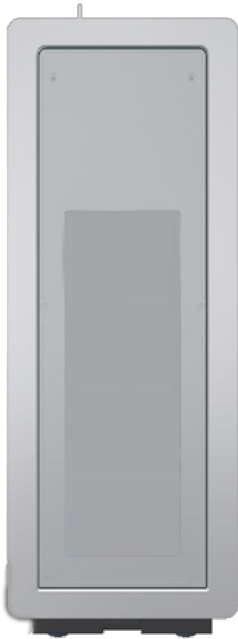

Our Flavor Station is available to you as an option for unusual creations. You can use the Flavor Station to extend your offerings with up to three different flavors.

5.2.4 Cup warmer

To enjoy coffee at its best, you need pre-heated cups. The cup warmer with four heatable shelves is the perfect match for your coffee machine.



5.2.5 Accounting system

The accounting system processes all payment transactions and records all accounting data.

Interfaces:

- VIP

Payment systems:

- Coin validator
- Coin changer
- Card readers

5.3 Overview of operating modes



The suitable operating mode depends on the utilization of your coffee machine, your product range and the preferences of your customers.

Your service technician will be happy to help you set the appropriate operating mode.

5.3.1 User interface

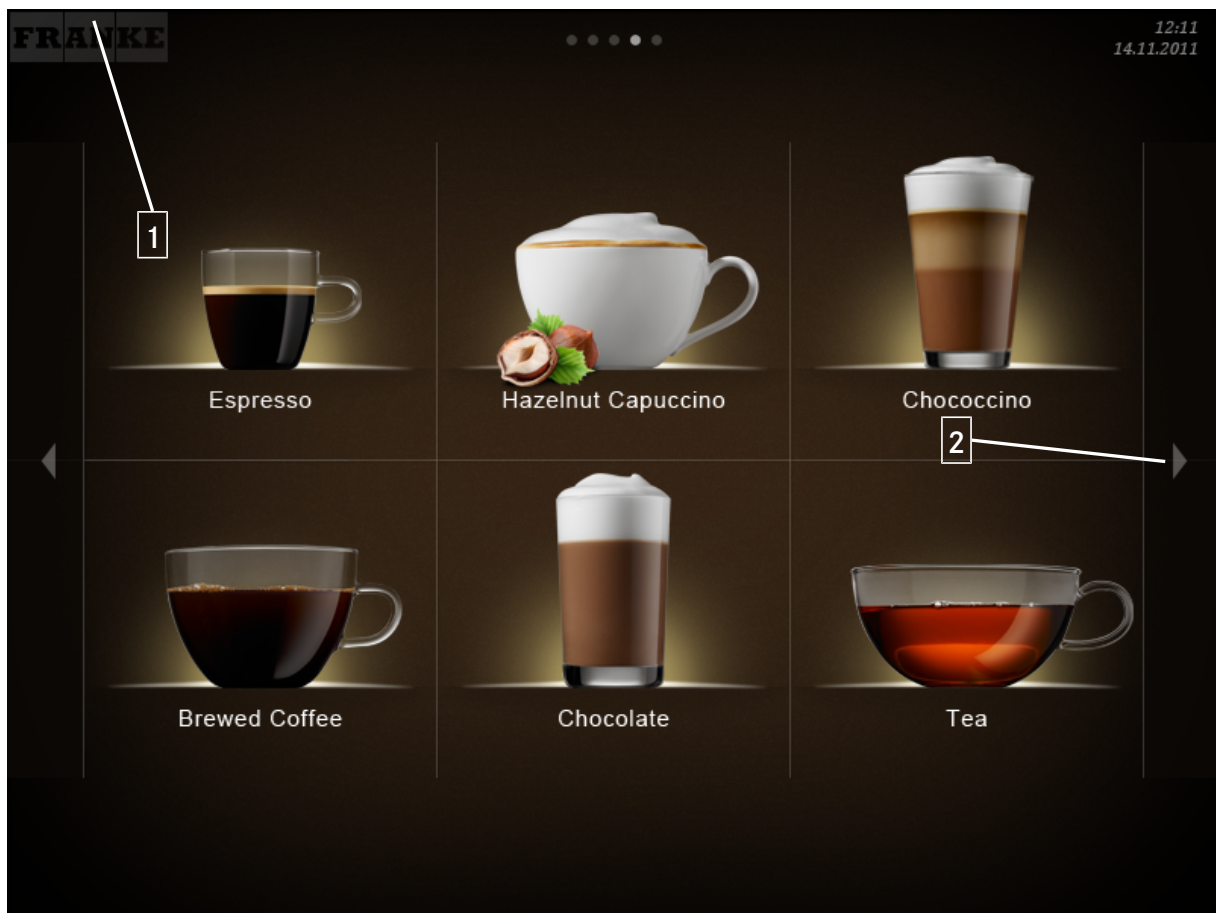

- 1 The Franke button is used to switch between the maintenance level and product selection.
- 2 Scroll forwards or backwards.

5.3.2 Cash Register operating mode



Cash Register is the operating mode for non-self-service utilization. You can add additional orders while your coffee machine is preparing a product.

Structure of the user interface

- Level 1: Product selection, up to 5 pages. Column with the possible options, the production status, and the waiting list
- Level 2: Display of 4, 9, or 16 product buttons per page

Individual adaptations

- Display: 2x2, 3x3, or 4x4 products per page
- Depiction: Photo-realistic, drawn

5.3.3 Quick Select operating mode



The **Quick Select** operating mode is the standard setting for self-service. Once your customer has selected a drink, he/she can adapt it in the second step if product options are activated.

Structure of the user interface:

- Level 1: Product selection, up to 5 pages
- Level 2: Drink Selection status; display of 6, 12, or 20 product buttons per page, select product options, start preparation (if activated)

Individual adaptations:

- Display: 2x3, 3x4, or 4x5 products per page
- Activate **Credit Mode**
- Individual arrangement of drinks

5.3.4 Operating mode Quick Select with Credit Mode



Display

- Product prices
- Credit
- Missing credit



In the **Drink Selection** status, you cannot add any drink options with the **Credit Mode** configuration. You can activate the **Credit Mode** in the **My settings** menu under **1 Set machine > 1.12 Payment**. Select **Activate payment**.

Menu item 1.12 Payment

5.3.5 Inspire Me operating mode

The **Inspire Me** operating mode is particularly suitable for self-service. The drinks can be aggregated in groups. You can thus present your customers with a clear overview of the drinks on offer.

Structure of the user interface:

- Level 1: Up to 6 menu cards with prefiltered selection
- Level 2: Up to 5 pages per menu card
- Level 3: 6 or 12 product buttons per page

Individual adaptations:

- Creation of menu cards
- Individual arrangement of drinks

6 INSTALLATION

6.1 Preparations

- The power connection for the coffee machine must be protected using a residual current circuit-breaker (RCCB).
- Each terminal of the power supply must be able to be interrupted using a switch.
- The mains water connection must meet the *Requirements of the water supply* [▶ 29] as well as the federal, state, and local regulations.
- The coffee machine must be connected to the water supply with the supplied hose set. Do not use any other water hoses that happen to be present.
- Make sure to provide a stable, ergonomic cup tray (min. load capacity 150 kg). The operator panel should be at eye level.



You must have completed these preparations before one of our service technicians can install the coffee machine for you. Your service technician will install your coffee machine and carry out the initial commissioning process. The technician will walk you through the basic functions.

6.2 Dimensions of the coffee machine with SU12 and other add-on units



The dimensions are specified in mm.

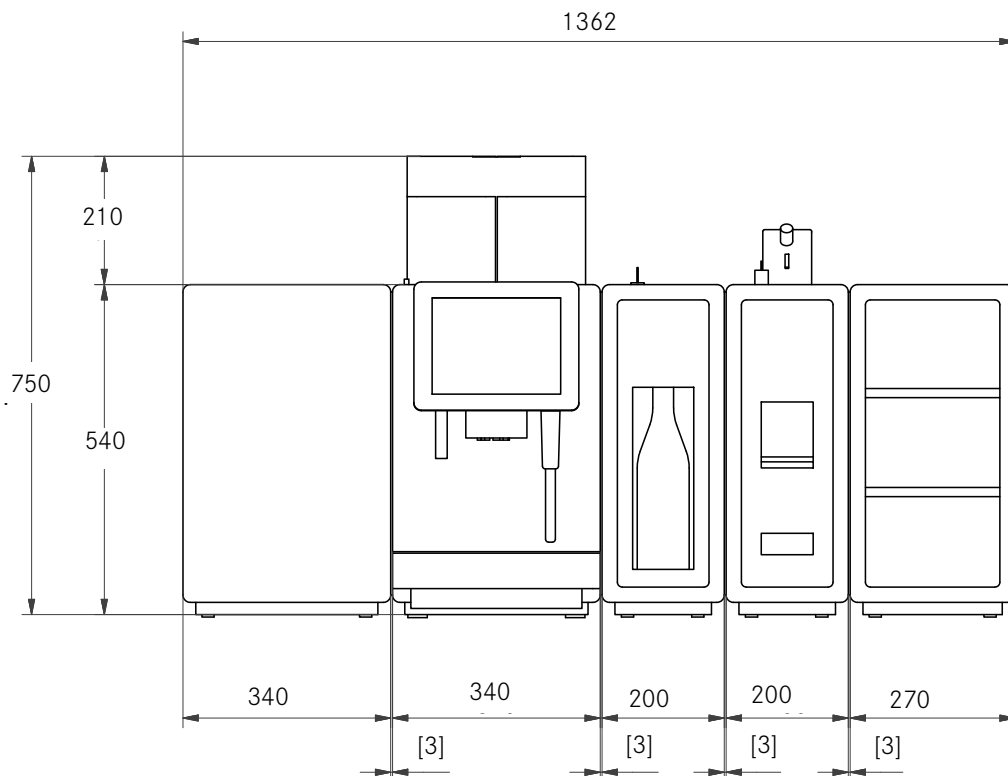

A800 with SU12 and other add-on units

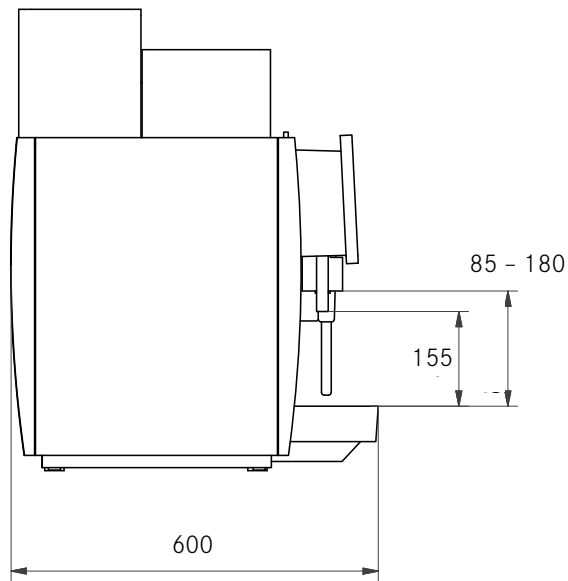

A800, side view

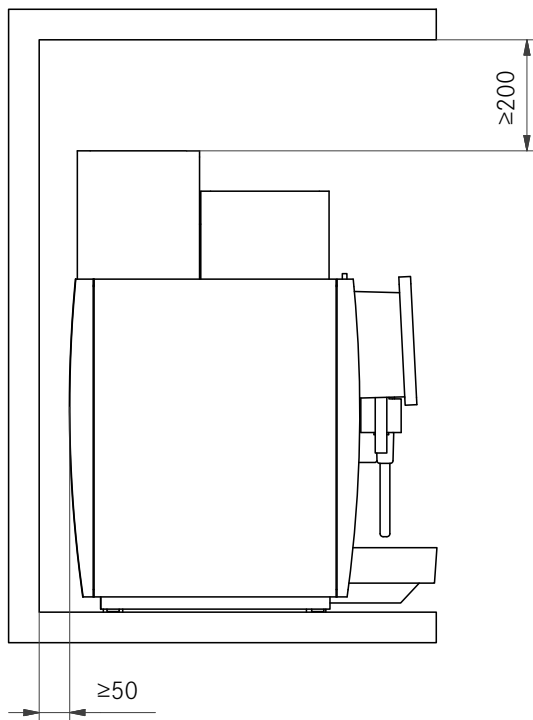

Dimensions at the installation location



NOTICE

Overheating damage

If the clearances around and above the machine are too small, heat may accumulate in the machine and lead to faults.

- a) Maintain the prescribed installation dimensions and clearances.
- b) Take care to ensure that the clearance spaces are not blocked.

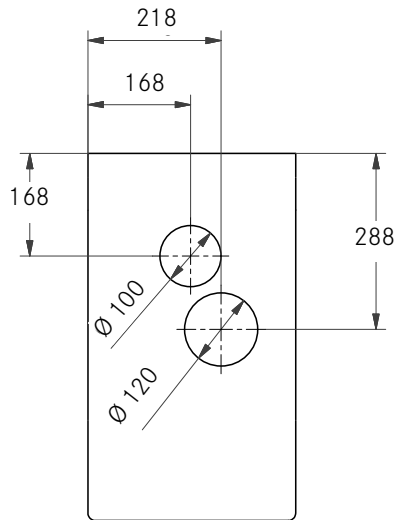

Hose feedthrough in the counter

6.2.1 Adjustable feet

Adjustable feet of 40 mm in height are included in the scope of delivery. Taller adjustable feet are also optionally available.

Height of adjustable feet	Total height
40 mm standard	750 mm + 40 mm = 790 mm
70 mm (option)	750 mm + 70 mm = 820 mm
100 mm (option)	750 mm + 100 mm = 850 mm

6.3 Requirements of the water supply

6.3.1 Water connection

Water pressure	80 – 800 kPa (0,8 – 8,0 bar)
Flow rate	> 0,1 l/sec
Water temperature	< 25 °C
Connection to the mains water connection	Union nut G3/8 and metal hose l = 1,5 m Only connect with the hose set provided

- The mains water connection must meet the requirements of the technical data and comply with applicable federal, state, and local regulations.

- The mains water connection must have a backflow prevention device.
- The mains water connection must be equipped with a shut-off valve and a check valve with an upstream filter accessible for inspection. It must be possible for the filter to be removed for cleaning.
- Water from a decalcification system must not be used.
- Filter with at least 100 loops/inch (UL)

6.3.2 Water quality

Total hardness:	4 – 8 dH GH (German total hardness) 7 – 14 fH GH (French total hardness) 70 – 140 ppm (mg/l)
Carbonate hardness	3–6 dH KH / 50–105 ppm (mg/l)
Acid content/pH value	6.5–7.5 pH
Chlorine content	< 0.5 mg/l
Chloride content	< 30 mg/l
TDS (total dissolved solids)	30 – 150 ppm (mg/l)
Electrical conductivity (measured)	50–200 $\mu\text{S}/\text{cm}$ (microsiemens)
Iron content	< 0.3 mg/l

- Color: Clear
- Taste: Fresh and pure taste
- Aroma: No perceptible aroma
- No rust particles in the water
- Reverse osmosis: The water must have a dissolved solids content of at least 30-50 ppm (30-50 mg/l) in order to prevent the boiler being overfilled.

Evaluating the risk of corrosion

The following formula can be used for evaluation:

Calculated conductivity = measured conductivity [$\mu\text{S}/\text{cm}$] – (measured total hardness [dH GH] x constant)

- Measured conductivity in $\mu\text{S}/\text{cm}$
- Measured total hardness in dH GH
- Constant = 30 [$\mu\text{S}/\text{cm}$]/[dH GH]

Calculated conductivity	Risk of corrosion
<200 $\mu\text{S}/\text{cm}$	low
200 – 500 $\mu\text{S}/\text{cm}$	increased
>500 $\mu\text{S}/\text{cm}$	high

Calculation example:

- Measured conductivity 700 $\mu\text{S}/\text{cm}$
- Measured total hardness 18 dH GH
- Calculated conductivity = 700 $\mu\text{S}/\text{cm}$ – (18 x 30 $\mu\text{S}/\text{cm}$) = 160 $\mu\text{S}/\text{cm}$

The result of the calculation is 160 $\mu\text{S}/\text{cm}$ and means that there is a low risk of corrosion.

6.3.3 Water outlet

- Two drain hoses: D = 16 mm, L = 2 m
- Connection to a lower-lying siphon

7 FILLING AND EMPTYING

7.1 Filling beans



WARNING

Risk of injury

If objects find their way into the bean hopper or grinder, splinters may be ejected, leading to injury.

- a) Never insert any objects into the bean hopper or grinder.



Fill the bean hoppers with coffee beans.

Fill the powder hopper with powder that is suitable for automatic coffee makers.



NOTICE

Poor drink quality

The oil from the coffee beans is deposited on the inside of the bean hopper as a thin film of oil. This deposited oil ages quickly and impairs the taste of the drinks produced.

- a) Remove the oil film from the inside of the bean hopper on a daily basis.
- b) To do this, use a dry cloth or a cloth moistened only with water.
- c) Do not use any cleaners, as these alter the taste of the coffee.



1. Lift off the bean hopper lid.



3. Replace the lid.



2. Add coffee beans.

7.2 Filling powder



1. Lift off the powder hopper lid.



3. Replace the lid.



2. Fill with powder that is suitable for automatic coffee makers.

7.3 Filling milk



CAUTION

Germs in unpasteurized milk

Germs in unpasteurized milk could pose a health hazard.

- a) Do not use any unpasteurized milk.
- b) Only use pasteurized or long-life milk.



NOTICE

Impaired drink quality

Incorrect handling of milk can lead to quality problems.

- a) Only clean containers should be filled with milk.
- b) Only use pre-cooled milk (2–5 °C).
- c) Only touch the inside of the milk container, the milk hoses, and the milk lid after sanitizing your hands, or wear disposable gloves.



NOTICE

Machine damage

Using incorrect liquids can damage the machine.

- a) Only fill the milk container with milk.
- b) Use water and a mild cleaner to clean the milk container.



The milk system is prepared semi-automatically after a cleaning or a filling procedure. Please observe the instructions in the event messages. Access to the event messages is through the dashboard.

7.3.1 Filling milk for the SU05 EC



1. Open the door.



2. Switch on the cooling unit.



⇒ The current cooling chamber temperature is displayed.

3. Remove the milk container lid with the suction hose and place it on a clean surface.



4. Fill the container with a maximum 5 l of cooled milk.

5. Attach the milk container lid.



6. Slide the milk container all the way into the cooling chamber.



7. Close the door.

7.3.2 Filling milk for the SU12

1. Open the door.
2. Switch on the cooling unit.
 - ⇒ The current cooling chamber temperature is displayed.



3. Only pull out the milk container until the sliding cover of the container lid is fully visible.
4. Push the sliding cover to the rear.
5. Fill the milk container with cooled milk.

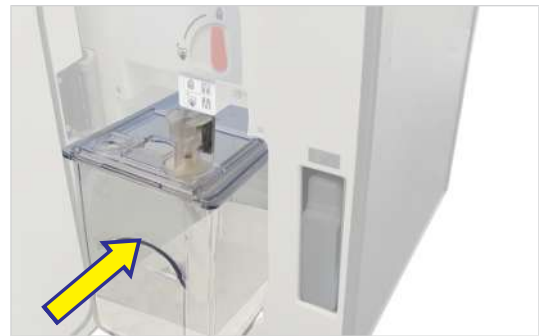

6. Slide the milk container all the way into the cooling chamber.



7. Close the door.

7.4 Filling the Flavor Station



The switch for switching the Flavor Station on is located inside, on the left-hand side of the rear panel.

1. Use the key to unlock the Flavor Station.
2. Press the release button and open the Flavor Station.
3. Switch on the Flavor Station.
4. Lift the bottle holders.
5. Place the bottles in the Flavor Station.
6. Pull the bottle holders down.
7. Slide the hose connection upwards and onto the hose.
8. Insert the hose into the bottle.
9. Push the hose connection into the top of the bottle.
10. Close the Flavor Station.

7.4.1 Preparing the Flavor Station



The Flavor Station must be prepared in the following cases:

- a) During the initial commissioning phase
 - b) Every time a syrup bottle is replaced
1. Switch to the maintenance level.
 2. Select **Cleaning and maintenance**.
 3. Select **Prepare Flavor Station**.
 4. Select and confirm **Start**.
 - ⇒ The syrup type is prepared.
 5. Observe instructions on the user interface.
 6. Repeat this step for each syrup bottle.

7.5 Setting the grind coarseness



⚠ WARNING

Risk of injury

If objects find their way into the bean hopper or grinder, splinters may be ejected, leading to injury.

- a) Never insert any objects into the bean hopper or grinder.



Grinder adjustment wrench (560.0003.876)



Changing the grind coarseness affects the coffee quantity. The grinders must therefore be calibrated after adjusting the grind coarseness.

If required, the grind coarseness can be set in stages for each grinder.



1. Pull the locking slide towards the front up to the stop.



2. Lift up bean hopper and powder hoppers.



3. If necessary adjust grind coarseness with the grinder adjustment spanner.

⇒ Turn counterclockwise for a finer grind.

⇒ Turn clockwise for a coarser grind.

4. Refit the bean hopper.
5. Check the grind produced and adjust if necessary.



6. Replace the bean hopper.



7. Push the locking slide all the way in.

7.6 Emptying the bean hopper



1. Pull the locking slide towards the front up to the stop.



2. Lift up bean hopper and powder hoppers.

3. Empty, clean, and dry the bean hopper.



4. Replace the bean hopper.



5. Push the locking slide all the way in.



NOTICE

Impairment of function

If the bean hopper and powder hopper are not locked correctly, the function of the coffee machine and the product quality may be impaired.

- a) Push the locking slide all the way in.

7.7 Emptying the powder hopper



NOTICE

Contamination from powder

Powder can fall from the powder hopper.

- a) Always transport the powder hopper in an upright position and ensure it is closed.



CAUTION

Cutting injuries/crushing

The powder hopper's feeding mechanism can cause cuts or crushing injuries.

- a) Exercise care when cleaning the powder hopper.



1. Pull the locking slide towards the front up to the stop.
2. Lift and remove the powder hopper.
3. Empty, clean, and dry the powder hopper.



4. Replace the powder hopper.



5. Push the locking slide all the way in.



NOTICE

Impairment of function

If the bean hopper and powder hopper are not locked correctly, the function of the coffee machine and the product quality may be impaired.

- a) Push the locking slide all the way in.

7.8 Emptying the grounds container



NOTICE

Formation of mold

Coffee residue can lead to the formation of mold.

- a) Empty and clean the grounds container at least once a day.

1. Open the door.
 - ⇒ The message **Door open** appears on the user interface.

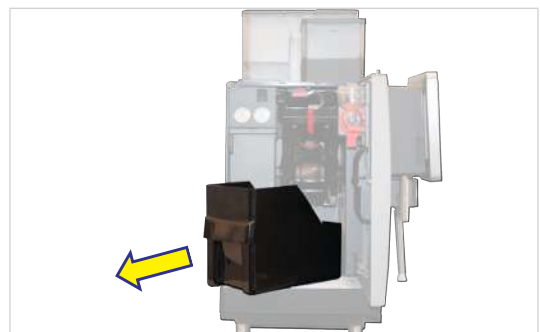

2. Remove the grounds container.

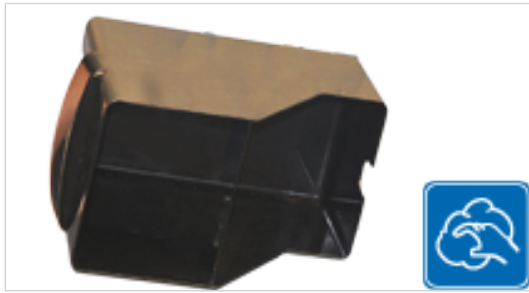

3. Empty, clean, and dry the grounds container.



4. Replace the grounds container and close the door.

7.9 Emptying the cooling unit



NOTICE

Spoiled milk

Insufficient cooling or hygiene can cause milk to spoil.

- a) Only use pre-cooled milk (2,0–5,0 °C).
- b) Only store milk in the cooling unit when the cooling unit is in operation. When the cooling unit is not in operation, e.g. overnight, store the milk in a refrigerator.
- c) Clean the machine and cooling unit once a day.
- d) Only touch the suction hose, the inside of the milk container, and the milk lid after sanitizing your hands, or wear disposable gloves.
- e) Place the container lid with the suction hose on a clean surface only.



CAUTION

Health hazard due to germ formation

Inadequate cleaning can result in food residues accumulating in the machine and at the outlets, thereby contaminating products.

- a) Do not use the machine unless it has been cleaned according to the instructions.
- b) Clean the machine daily in accordance with the instructions.
- c) Inform operating personnel of the necessary cleaning measures.



1. Open the door.



2. Pull out the milk container.



3. Store the milk in a refrigerator or dispose of it if necessary.



4. Clean the milk container, the parts that come into contact with milk, and the cooling chamber.



5. Insert the clean milk container.



6. Switch off the cooling unit if it is no longer required. After switching off, do not close the cooling unit door all the way, but leave it slightly open in order to prevent the formation of odors.

8 PREPARING DRINKS



⚠ WARNING

Risk of scalding

Hot drinks can lead to scalding.

- a) Always be careful with hot drinks.
- b) Use only suitable drinking vessels.

8.1 Dispensing drinks with Quick Select

1. Place an appropriate drinking vessel under the spout.
2. Select a product.
 - ⇒ The Drink Selection product preview appears.



3. Select product options.

4. Start preparation with the green button.
 - ⇒ Preparation begins.



- ⇒ The product selection screen appears when the drink is ready.

8.2 Preparing drinks with Cash Register



When preparing several products one after the other, please observe the following:

- a) Have sufficient drinking vessels ready to use.
- b) You can continuously add new products to the waiting list during the preparation.
- c) You can select and clear products from the waiting list.

1. Place an appropriate drinking vessel under the spout.



2. Select product options.



3. Select a product.
 - ⇒ Preparation begins.



4. Add more products to the waiting list as needed.



5. Start preparation of each of the products in the waiting list by pressing the green button.

⇒ The next preparation begins.

⇒ The product selection appears.

⇒ All products are ready.

8.3 Dispensing drinks with Inspire Me

1. Place an appropriate drinking vessel under the spout.
2. Scroll through the menu cards.
3. Tap on the desired menu card with your finger.
 - ⇒ The drinks overview appears.
4. Select a product.
 - ⇒ The Drink Selection product preview appears.

5. Select product options.
 - ⇒ The spout lowers.
 - ⇒ Preparation begins.
 - ⇒ Menu cards appear.
6. Start preparation with the green button.
 - ⇒ The product is ready.

8.4 Preparing a drink with ground coffee

Example: Quick Select



Only ground coffee may be used. Instant coffee made from dried coffee extract cannot be used.

1. Place an appropriate drinking vessel under the spout.



2. Press the **Decaffeinated coffee** selection button.

⇒ The **Decaffeinated coffee** selection button illuminates.

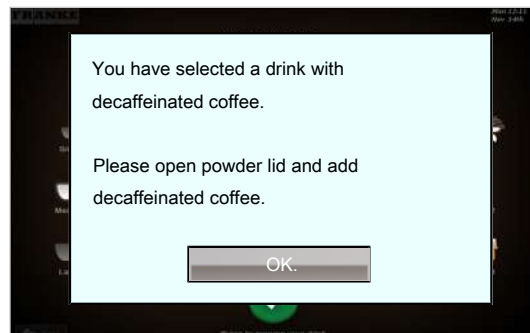

⇒ The following message appears:



3. Open the insertion flap.

4. Fill powder.



5. Close the insertion flap.

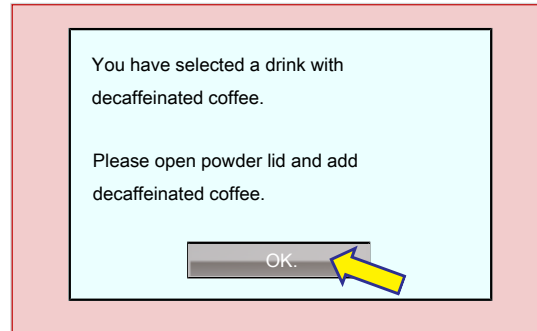

6. Confirm with OK.

⇒ Preparation begins.

⇒ The product selection appears.

⇒ The product is ready.

8.5 Preparing hot water

Example: Quick Select



1. Place an appropriate drinking vessel under the hot water spout.



2. Select Tea.



3. Select cup size.

⇒ Hot water is dispensed until the cycle is complete.



You can stop the hot water dispenser at any time by pressing the cancel button.

8.6 Steam output

1. Hold a suitable container under the steam wand.

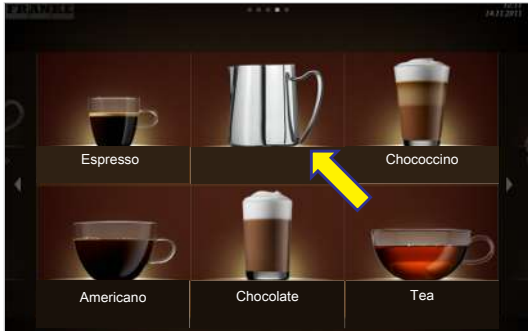

2. Select **Steam output**.

⇒ The steam output starts.

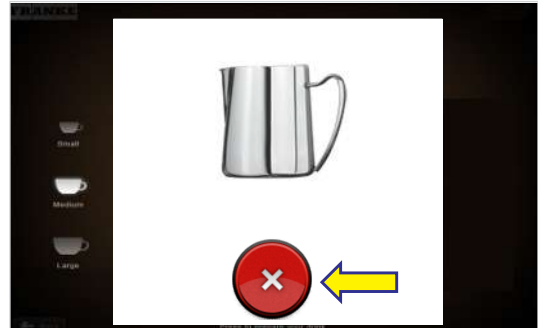

3. Press the cancel button to stop the steam output.

⇒ The steam output stops.

⇒ The drinks overview screen appears.



Depending on the model of the steam wand, the steam output is automatically stopped when your drink has reached the specified temperature (Autosteam/Autosteam Pro) or the steam output cycle has ended (steam wand). Independent of this, the steam output can be ended at any time by pressing the cancel button.

8.6.1 Purging the steam wand after use

1. Wipe the steam wand with a damp cloth.

2. Start the steam output briefly to purge the nozzle.

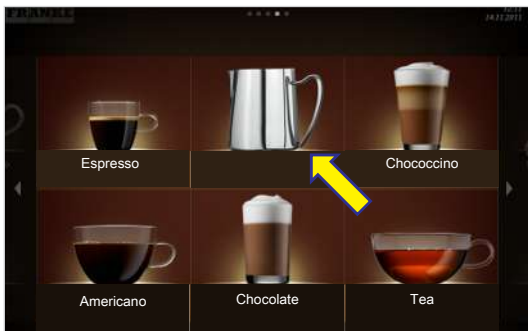

3. Press the cancel button to stop the steam output.



⇒ The steam output stops.

⇒ The drinks overview screen appears.

8.7 Steam dispenser (Autosteam/Autosteam Pro)



Autosteam is suitable for manually heating and foaming/frothing of milk and for heating other drinks.



Using the purging function will remove any condensation from inside the steam wand.

1. Press the purge button .



2. Hold a suitable container under the steam wand.

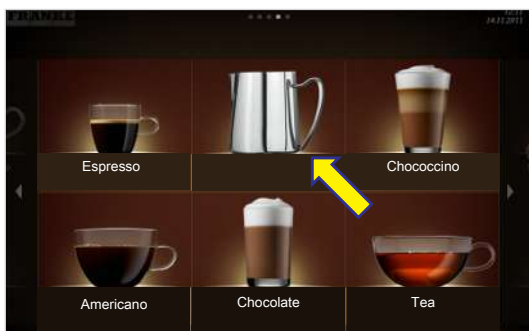
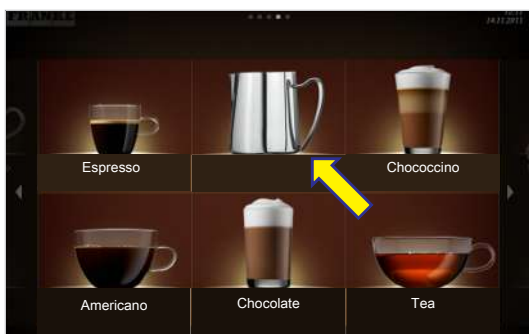

3. Select **Steam output**.

⇒ The steam output starts.

⇒ The steam output is automatically stopped when your drink has reached the specified temperature.

⇒ The drinks overview screen appears.

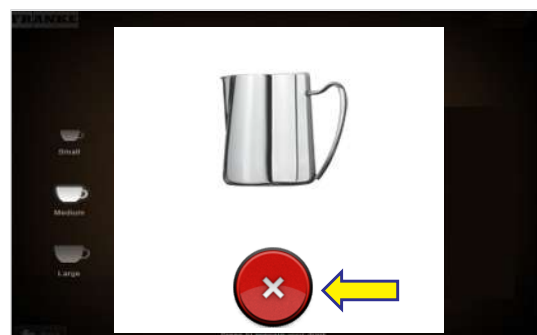

4. If required, press the cancel button to stop the steam output.

5. Press the purge button .

9 CLEANING

9.1 Introduction

The perfect coffee experience depends on a perfectly cleaned coffee machine. Clean your coffee machine at least once a day and more frequently if necessary.



NOTICE

Incorrect cleaning of the brewing unit

Damage may occur if the the brewing unit is cleaned in the dishwasher.

- a) Clean the brewing unit rinsing it under tap water.



NOTICE

Soiled accessories

Soiled accessories can have a negative affect on the functionality of the machine and the quality of the drinks produced.

- a) Clean the accessories by using the 5-step method.
- b) Follow the applicable instructions for accessories.

The automatic cleaning process involves cleaning the coffee machine and cleaning the cooling unit.

Other areas to be cleaned:

- Inner surfaces of the cooling chamber
- Inner side of the door and lip seal
- Milk container and milk container lid
- Milk suction hose, suction fitting, flow / no flow adapter (SU12 only)
- Bean hopper and powder container

9.2 5-step method



Clean the removable components of your coffee machine using the 5-step method.

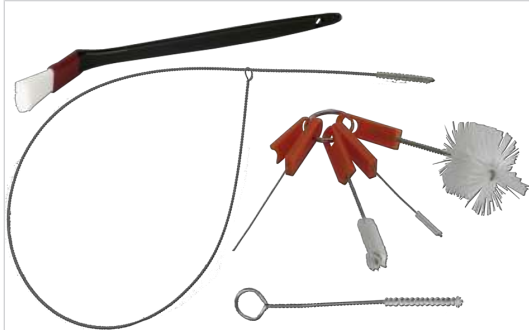

1. Remove coarse dirt with a cleaning brush or brush.



2. Soak the parts in hot water with a mild cleaner.



3. Wash the parts.



4. Rinse the parts thoroughly.



5. Dry the parts.

9.3 Required cleaning accessory

9.3.1 Cleaning accessories for MS EC

- Cleaning tablets
- Microfiber cloth
- Brush set
- Milk system cleaning agent (dosing bottle)
- Cleaning container

9.3.2 Cleaning accessories for FM CM

- Cleaning tablets

- Microfiber cloth
- Brush set
- Milk system cleaning agent

9.4 Starting the cleaning process



The automatic cleaning process includes the cleaning of the coffee machine, cooling unit and Flavor Station (if applicable).

9.4.1 Starting cleaning via the Cleaning and Maintenance menu

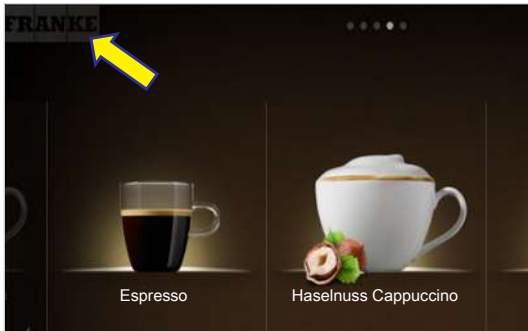

1. Tap the Franke logo.

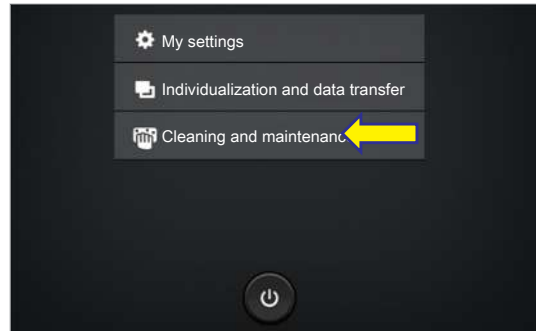

4. Select **Cleaning and maintenance**.



2. Enter the PIN. *PIN codes [► 51]*

3. Press **OK**..

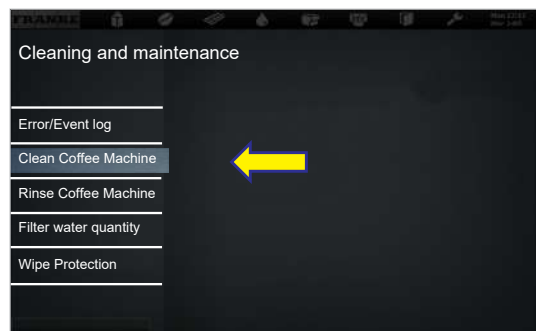

5. Select **Clean coffee machine**.

6. Confirm message with **Yes** to begin the cleaning process.

7. Follow the instructions on the user interface and confirm the individual steps by selecting **Next**.

⇒ The machine shows the next step.



WARNING

Risk of scalding

Hot liquids and steam escape during cleaning and can lead to scalding.

- a) Keep hands away from the spouts and nozzles during this process.



When the cleaning cycle is complete, the machine either switches back to the maintenance level or the energy saving mode. Your service technician can set the desired option for you.

9.5 Rinsing coffee machine



⚠ WARNING

Risk of scalding

Hot water is released during rinsing.

- Keep hands away from the spouts and nozzles during this process.
- Do not place anything on the drip grid.
- IN CASE OF SCALDING: Immediately cool the affected area and, depending on the severity of the injury, consult a doctor.



Rinsing is not a substitute for daily cleaning! Rinsing is necessary to remove residue build-up in the coffee and milk systems.

The machine automatically rinses after certain time intervals as well as when it is switched on or off.

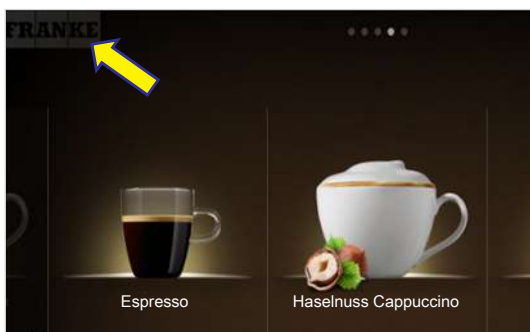

1. Tap the Franke logo.

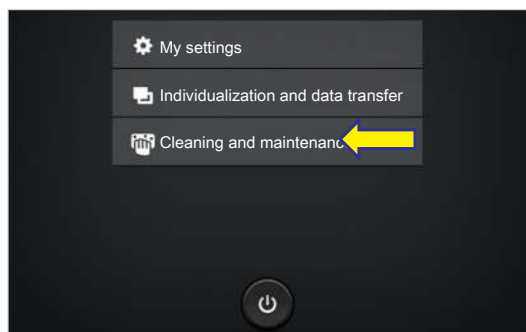

4. Select **Cleaning and maintenance**.



2. Enter the PIN. *PIN codes [▶ 51]*

3. Press **OK**.

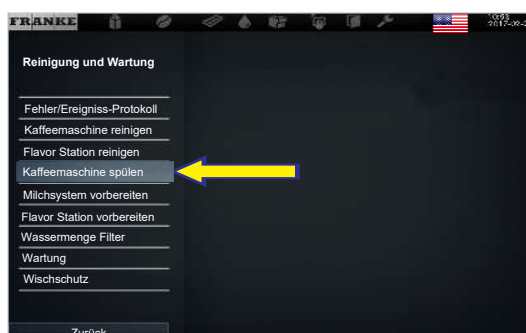

5. Select **Rinse coffee machine** and confirm.

⇒ The coffee machine is being rinsed.

9.6 Cleaning the aerator



1. Remove the aerator for hot water with the tool and descale.

9.7 Cleaning the Autosteam Pro/S3 components

1. Switch off the machine.
2. Open the door. Leave the door open while cleaning.

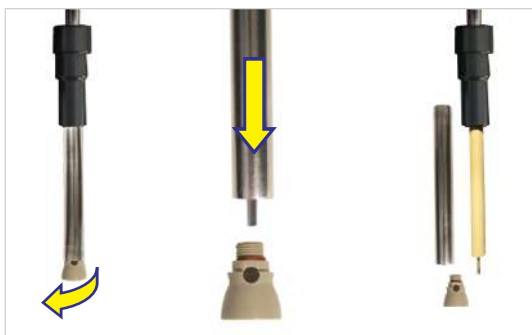

3. Unscrew the steam nozzle.
4. Pull the protective tube downwards.



5. Clean the inside of the steam nozzle with a brush.



6. Soak the protective tube and steam nozzle in hot water using a mild cleaner.
7. Thoroughly clean and rinse the protective tube and steam nozzle.



8. Clean the steam pipe on the machine with a cloth.



9. Slide the protective tube onto the steam pipe and attach the steam nozzle.

10. Close the door.



11. Wipe the steam wand with a cloth.

9.8 Cleaning the screen



You cannot cancel the locking function of the user interface. The locking function lasts 20 seconds.



1. Tap the Franke logo.

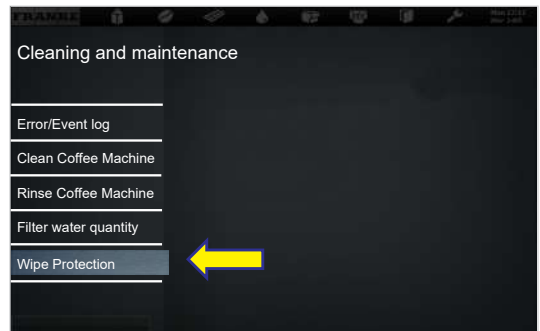

5. Select **Wipe Protection**.

⇒ The user interface is locked for 20 seconds.



2. Enter the PIN. *PIN codes [► 51]*

3. Press **OK**..

6. Clean the screen.

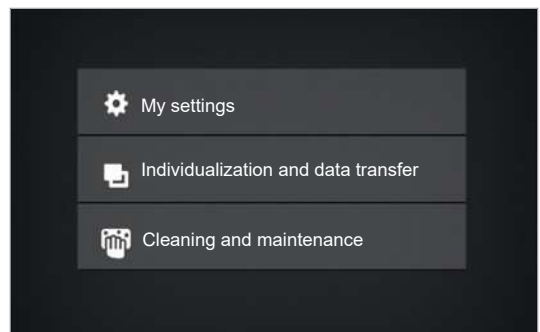

⇒ The maintenance level appears.

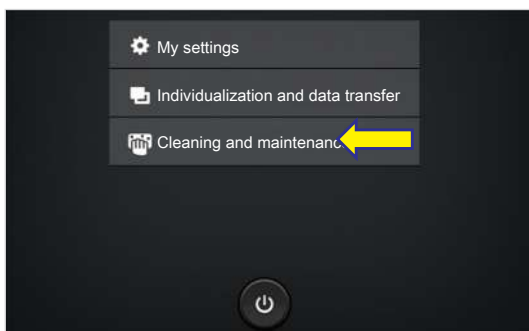

4. Select **Cleaning and maintenance**.

10 CONFIGURATION

10.1 Switching to the maintenance level



1. Tap the Franke logo.



2. Enter the PIN. *PIN codes [► 51]*

3. Press OK..

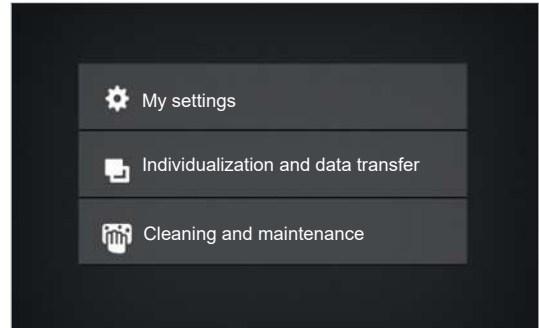

4. Select Menu.

10.2 PIN codes

Default PIN codes are assigned at the factory:

	Owner	Specialist	Operator
Default PIN	1111	2222	7777
My PIN

The PIN codes for key-secured products and On/Off machine can be viewed and changed with the owner role in the **My settings/6 Access rights** menu.

10.3 My settings menu tree

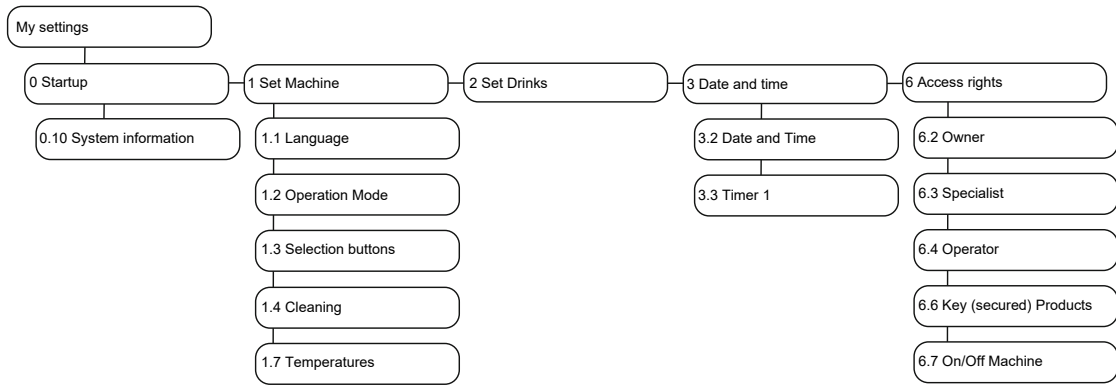

Depending on the configuration of your machine, individual menu items may or may not be displayed.

10.4 Input methods



Tap the switch to switch between **Yes/No** or **On/Off**. The visible value is active.

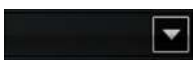

Tap the arrow to display the selection and to select the option.



Drag the scale to adjust parameters. The framed value is active.



Tap the keyboard to enter text or numbers.

10.5 Menu 0 Commissioning

10.5.1 Menu item 0.10 System information

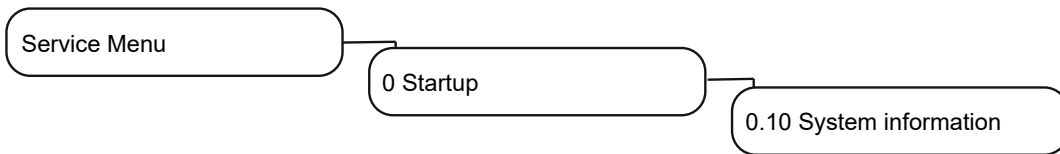

Here you will find information regarding the hardware and software versions of the machine.

10.6 Menu 1 Set machine

You can customize your machine to suit your requirements via the menu **1 Set Machine**. The following options are available.

- Set language
- Configure operating mode
- Assign selection buttons

- Set cleaning function
- Change temperature settings

10.6.1 Menu item 1.1 Language

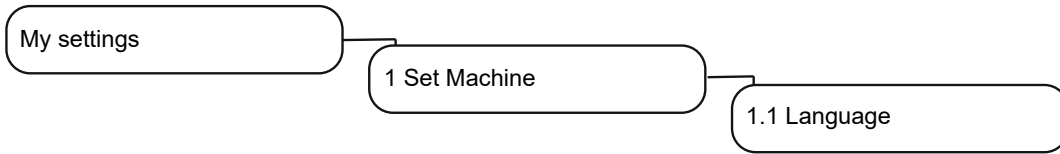

Parameter	Value range	Remarks
Select language	de, en, fr, bg, cs, da, es, es-US, et, fi, fr-CA, hr, hu, it, ja, ko, lt, lv, nl, no, pl, pt-BR, ro, ru, sk, sl, sr, sv, tr, uk, zh-CN, zh-TW	<ul style="list-style-type: none"> - The language is switched immediately on the user interface - Default: de (German)

10.6.2 Menu item 1.2 Operating mode

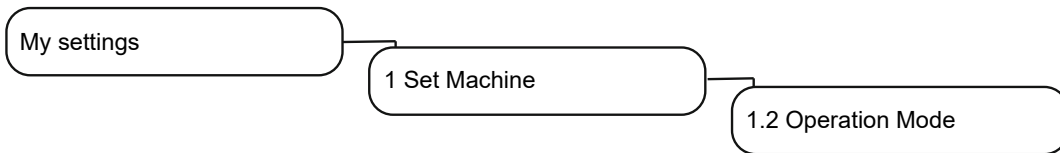

Operation mode

Usage scenario > Non-self-service

Parameter	Value range	Remarks
Usage scenario	<ul style="list-style-type: none"> - Non-self-service - (Self-service) 	
Products per page	<ul style="list-style-type: none"> - 4 - 9 - 16 	<ul style="list-style-type: none"> - Number of products displayed simultaneously - Default: 4
Depiction	<ul style="list-style-type: none"> - Photo-realistic - Iconized 	Default: Photo-realistic
Automatic mode	<ul style="list-style-type: none"> - Yes - No 	<ul style="list-style-type: none"> - Yes: All pre-selected products are dispensed without additional button input - No: Each product must be triggered with the start button - Default: No
Pause between products	1 - 10 seconds	<ul style="list-style-type: none"> - Appears if the Automatic mode is activated - Increment: 1
Shot timer	<ul style="list-style-type: none"> - Yes - No 	
Display "purge steam wand"	<ul style="list-style-type: none"> - Yes - No 	Default: No

Usage scenario Self-service

Usage scenario > Self-service

Parameter	Value range	Remarks
Usage scenario	<ul style="list-style-type: none"> - Self-service - (Non-self-service) 	
Operation Mode	<ul style="list-style-type: none"> - Quick Select - Inspire Me 	<ul style="list-style-type: none"> - Default: Quick Select - A choice can be made between Quick Select and Inspire Me for the "self-service" usage scenario (Inspire Me is not available for A400).
Products per page	<ul style="list-style-type: none"> - 6 - 12 - 20 	<ul style="list-style-type: none"> - Number of products displayed simultaneously - Default: 6
Adapt drinks	<ul style="list-style-type: none"> - Yes - No 	<ul style="list-style-type: none"> - Possibility for self-service customers to modify the selected drink in accordance with the allocation of the selection buttons - Default: No
Custom images	<ul style="list-style-type: none"> - Yes - No 	<ul style="list-style-type: none"> - Activate customer-specific images - For usage scenario Self-service, operating mode Quick Select - Default: No

Options

Parameter	Value range	Remarks
Key (secured) products	<ul style="list-style-type: none"> - Yes - No 	<ul style="list-style-type: none"> - Selected products can be blocked with the Key (secured) products option - Key (secured) products can be prepared only after a PIN code has been entered (see Chap. 6. Access rights, p. 105) - Default: No

10.6.3 Menu item 1.3 Selection buttons

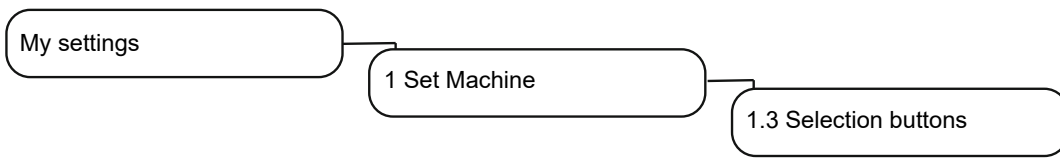

Parameter	Value range	Remarks
Product options	<ul style="list-style-type: none"> - Small - Medium - Large - 2x - Decaf - Flavor 1 - 6 - Extra Shot - Iced - Espresso Shot 	<ul style="list-style-type: none"> - A maximum of twelve selection buttons can be assigned with various product options in the service menu. The product options appear in the Drink Selection status - With up to eight configured selection buttons, buttons 1 - 4 are displayed on the left-hand side, with the rest on the right-hand side - If more than eight selection buttons are configured, buttons 1 - 6 are displayed on the left-hand side, with the rest on the right-hand side - Nine or more buttons are displayed at a reduced size <p>Recommendation:</p> <ul style="list-style-type: none"> - Selection buttons on the left-hand side: Select drink size. - Selection buttons on the right-hand side: Select additional settings.
Text display	<ul style="list-style-type: none"> - Function - Free text - No text 	<ul style="list-style-type: none"> - Default: Function: Labeling corresponds to the name of the selected product option. - Free text: Enter your own labeling of the selection buttons. - No text: Switch off labeling.
Price	Amount	<ul style="list-style-type: none"> - Store surcharge for the option. - The total price is calculated by the machine - Default: 0.00
PLU	PLU no.	<ul style="list-style-type: none"> - Store PLU number of price calculation (if PLU numbers are used). - Default: 0

10.6.4 Menu item 1.7 Temperatures

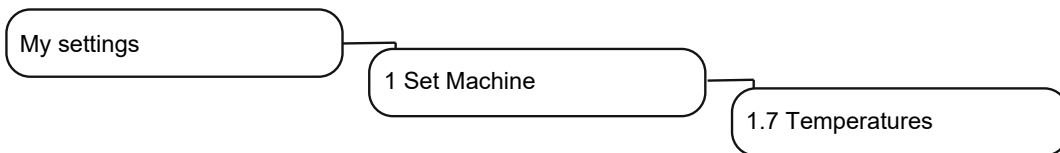

For these settings, consider the location, the ambient temperature, and the capacity utilization of the machine.

Parameter	Value range	Remarks
Coffee	-20 to +20	<ul style="list-style-type: none"> - The temperature in the coffee boiler is preset by the service technician - The set temperature can be adjusted by percentages using the sliding controller
Steam	-20 to +20	<ul style="list-style-type: none"> - The temperature in the steam boiler is preset by the service technician - The set temperature can be adjusted by percentages using the sliding controller
Tea water	-20 to +20	<ul style="list-style-type: none"> - The temperature in the hot water boiler is preset by the service technician - The set temperature can be adjusted by percentages using the sliding controller

10.6.5 Menu item 1.10 Milk system

Parameter	Value range	Remarks
Configuration version	<ul style="list-style-type: none"> - No milk system - FoamMaster - Milk system - FM EC - FoamMaster Twin - Two Step 	Display of the milk system that was configured under Menu item 0.1 Machine
Milk type 1		Display of the Milk type 1 that was configured under Menu item 0.2 Configuration
Milk type 2		Display of the Milk type 2 that was configured under Menu item 0.2 Configuration

Parameter	Value range	Remarks
Monitoring	<ul style="list-style-type: none"> - W: Wall - L: Milk tubes - W/L: Wall and milk line - Without 	<ul style="list-style-type: none"> - W: Inner wall: The fill level of the milk is monitored via a capacitive sensor on the inner side wall of the cooling unit - The following error messages appear if the minimum level is not reached: <ul style="list-style-type: none"> Milk 1: E620, after the time set under empty message has expired E619 Milk 2: E622, after the time set under empty message has expired E621 - When milk has been refilled, the milk system will be prepared automatically when a milk product is dispensed - L: Milk tube: The fill level of the milk is monitored by a conductive sensor in the milk tube. <ul style="list-style-type: none"> If no milk is flowing through the line, the error messages 617 (milk 1) and 618 (milk 2) appear. The dispensing of a milk product is canceled immediately and the products are blocked If the milk runs out when a milk product is dispensed, the error message 'Product cancellation due to insufficient whole milk' will appear. The user then has the opportunity to add milk via a guided process, prepare the milk system, and repeat the canceled product output. If the process is ended by the user, the money that has been paid into the machine is forfeited when the accounting system is switched on - Without: No fill level monitoring of the milk - Default FM: Wall - Default MS: Milk tube
Empty Message	0 - 40 s	<ul style="list-style-type: none"> - The parameter is only displayed in the case of monitoring W: Inner wall - Default: 30.0 s

10.6.6 Menu item 1.11 Flavor

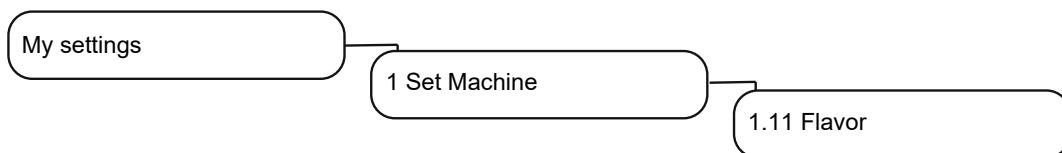

Parameter	Value range	Remarks
Counting is active	<ul style="list-style-type: none"> - Yes - No 	<ul style="list-style-type: none"> - Yes: Flavor products are counted - No: Flavor products are not counted - Default: No

Flavor 1 - 6

Parameter	Value range	Remarks
Flavor 1-6	List of syrup types	<ul style="list-style-type: none"> Only the flavor types stored here will be available later for the drinks settings If User-defined is selected, the flavor types can be named according to preference
Flavor name 1 - 6	User-defined	Any name can be entered for the flavor types Note: The manually entered flavor types are not switched when the language is changed
Only a small amount of syrup left	0-5,000 ml	<ul style="list-style-type: none"> Input of residual amount for which the Syrup type 1 almost empty message appears Default: 200 ml
Syrup empty	0-5,000 ml	<ul style="list-style-type: none"> Input of residual amount for which the Syrup type 1 empty message appears. The syrup type is then locked Default: 10 ml

10.6.7 Menu item 1.14 Edge lighting

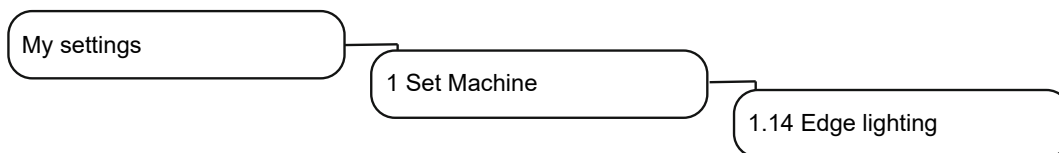

Parameter	Value range	Remarks
Select lighting	<ul style="list-style-type: none"> Off Red, green, blue, yellow, cyan, magenta, white Flash Color gradient User-defined 	<ul style="list-style-type: none"> Off: No edge lighting Red, green, etc.: Edges illuminated in the selected color Flash: Flashing light Color gradient: Color changes continuously User-defined: Colors can be defined individually by the input of RGB values Default value: Color gradient
Edge lighting red	0 - 100%	Input of RGB values for a user-defined color
Edge lighting green		
Edge lighting blue		
Error display on edge lighting	<ul style="list-style-type: none"> Yes No 	<ul style="list-style-type: none"> Yes: Error display on edge lighting active No: No error display via edge lighting

10.7 Menu 3 Date and time

10.7.1 Menu item 3.2 Date and time

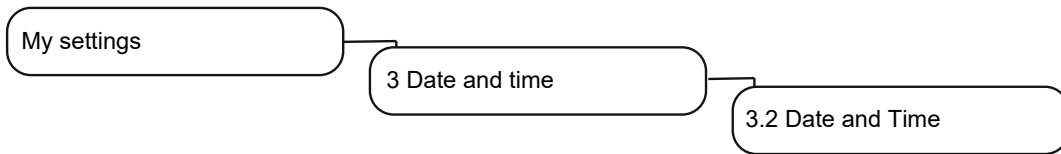

Parameter	Value range	Remarks
12/24-hour display	- 12 hours - 24 hours	
Day	0-31	Set the day
Month	0-12	Set the month
Year	0-63	Set the year
Hour	0-23/0-11	Configure hours
Minute	0-59	Configure minutes
Time zone	Time zone selection list	- Select the time zone from the list - Default: UTC+0100 (Europe) Zurich

10.7.2 Menu items 3.3-3.6 Timer 1-4

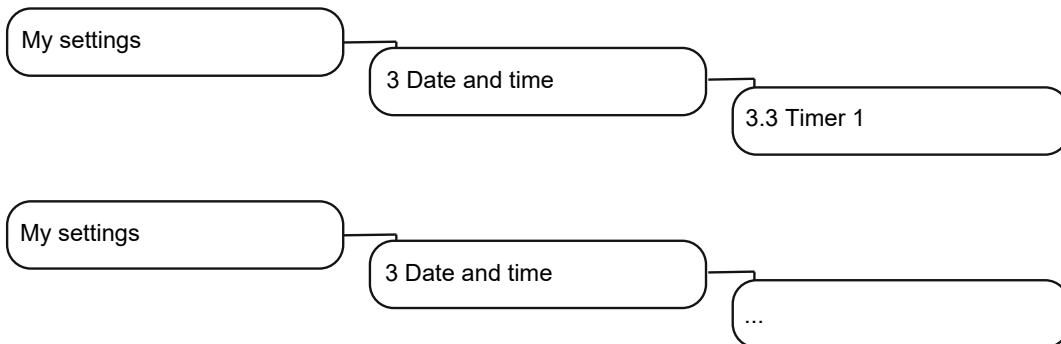

Switch on automatically

Parameter	Value range	Remarks
Active	- Yes - No	Switch timer on or off
Hour	0 - 23/0 - 11	Select switch-on time (hour)
Minute	0 - 59	Select switch-on time (minute)
Monday, Tuesday, Wednesday, Thursday, Friday, Saturday, Sunday	- Yes - No	Activate or deactivate the timer for each day

Switch off automatically

Parameter	Value range	Remarks
Active	- Yes - No	Switch timer on or off
Hour	0 - 23/0 - 11	Select switch-off time (hour)
Minute	0 - 59	Select switch-off time (minute)
Monday, Tuesday, Wednesday, Thursday, Friday, Saturday, Sunday	- Yes - No	Activate or deactivate the timer for each day

10.8 Menu 4 Nutritional value information

10.8.1 Menu item 4.1 Milk

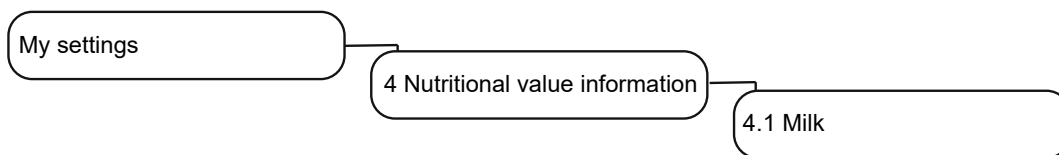

Milk type 1/Milk type 2

Enter nutritional values per 100 ml

Parameter	Value range	Remarks
Sugars	Number	Enter sugar content in g per 100 ml
Fat (%)	Number	Enter fat content in %
Protein (g)	Number	Enter protein content in g per 100 ml of powder
Calories	Number	Enter calorific value in kilocalories (kcal)
[List of common allergens and ingredients]	- Yes - No	- Enter ingredients or allergens for the milk type used - Default: No
Other allergens	User-defined	Enter ingredients or allergens that are not included in the list

10.8.2 Menu item 4.2 Flavor

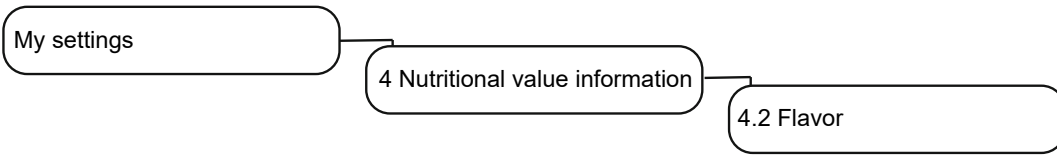

Flavor 1-3

Enter nutritional values per 100 ml

Parameter	Value range	Remarks
Sugars	Number	Enter sugar content in g per 100 ml
Fat (%)	Number	Enter fat content in %
Protein (g)	Number	Enter protein content in g per 100 ml of powder
Calories	Number	Enter calorific value in kilocalories (kcal)
[List of common allergens and ingredients]	<ul style="list-style-type: none"> - Yes - No 	<ul style="list-style-type: none"> - Enter ingredients or allergens for the milk type used - Default: No
Other allergens	User-defined	Enter ingredients or allergens that are not included in the list

10.8.3 Menu item 4.3 Powder

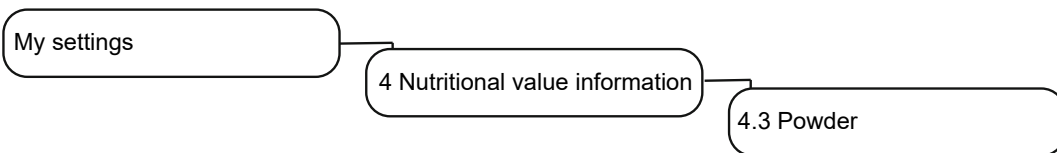

Powder dosing unit position 3/4

Enter nutritional values per 100 ml

Parameter	Value range	Remarks
Sugars	Number	Enter sugar content in g per 100 ml
Fat (%)	Number	Enter fat content in %
Protein (g)	Number	Enter protein content in g per 100 ml of powder
Calories	Number	Enter calorific value in kilocalories (kcal)

Parameter	Value range	Remarks
[List of common allergens and ingredients]	<ul style="list-style-type: none"> - Yes - No 	<ul style="list-style-type: none"> - Enter ingredients or allergens for the milk type used - Default: No
Other allergens	User-defined	Enter ingredients or allergens that are not included in the list

10.9 Menu 6 Access rights



The access rights option makes it possible to assign different PIN codes for different tasks and roles. Three access levels (owner, specialist, and operator) can be defined for accessing the maintenance level.

Menu item	PIN code (default values)
6.2 Owner	1111
6.3 Specialist	2222
6.4 Operator	7777
6.6 Key (secured) Products	8888
X6.8/X6.7	9999

10.9.1 Menu item 6.2 Owner

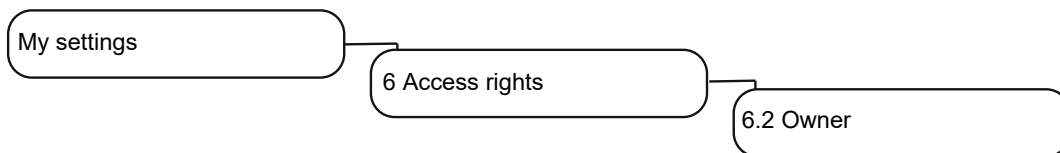

Parameter	Value range	Remarks
4 digits	Enter new PIN	<ul style="list-style-type: none"> - Authorizations: Access to My settings; call up Counters - Default PIN: 1111
PIN set	<ul style="list-style-type: none"> - Yes - No 	<ul style="list-style-type: none"> - Yes: PIN is set and being used - No: PIN is not being used

10.9.2 Menu item 6.3 Specialist

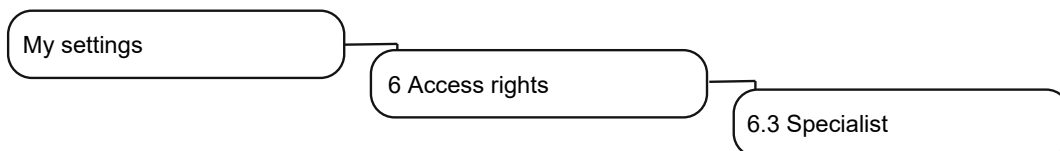

Parameter	Value range	Remarks
4 digits	Enter new PIN	<ul style="list-style-type: none"> - Authorizations: Limited access to My settings; call up product counters - Default PIN: 2222

Parameter	Value range	Remarks
PIN set	- Yes	- Yes: PIN is set and being used
	- No	- No: PIN is not being used

10.9.3 Menu item 6.4 Operator

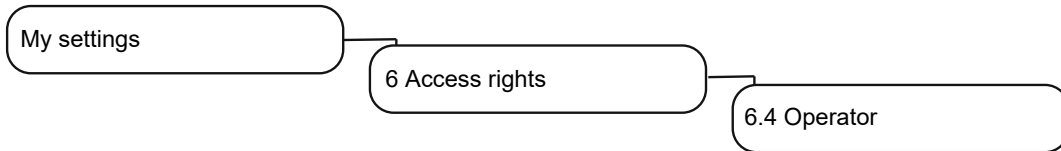

Parameter	Value range	Remarks
4 digits	Enter new PIN	- No access to My settings ; call up product counters; call up Counters - Default PIN: 7777
PIN set	- Yes	- Yes: PIN is set and being used
	- No	- No: PIN is not being used

10.9.4 Menu item 6.6 Key (secured) products

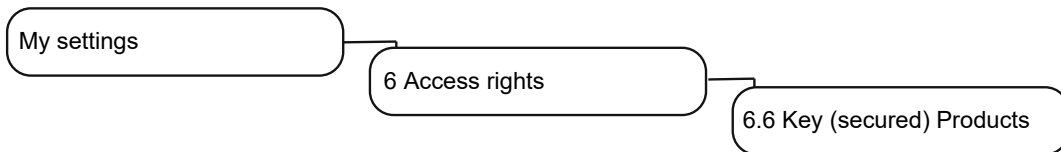

Parameter	Value range	Remarks
4 digits	Enter new PIN	
PIN set	- Yes	- Yes: PIN is set and is being used in locked products
	- No	- No: PIN is not being used

10.9.5 Menu item 6.7 On/Off machine

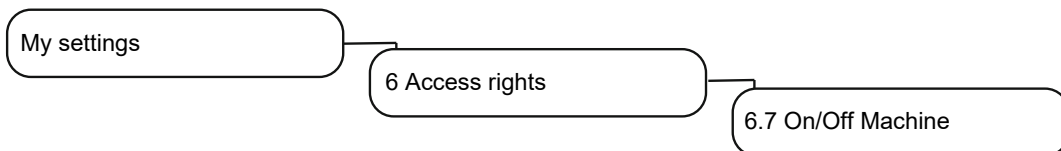

Parameter	Value range	Remarks
4 digits	Enter new PIN	
PIN set	- Yes	- Yes: PIN is set and being used
	- No	- No: PIN is not being used

11 INDIVIDUALIZATION AND DATA TRANSFER

11.1 Overview

This menu provides you with the following options:

- Use existing Franke media for drinks, screen savers, or as advertising media
- Upload and view your own media objects on the machine
- Use your own media for drinks, screen savers, or as advertising media
- Configure the behavior of the various operating modes and screen savers
- Saving the settings
- Create regular backups of your machine to a USB stick

11.2 Individualization and data transfer menu tree

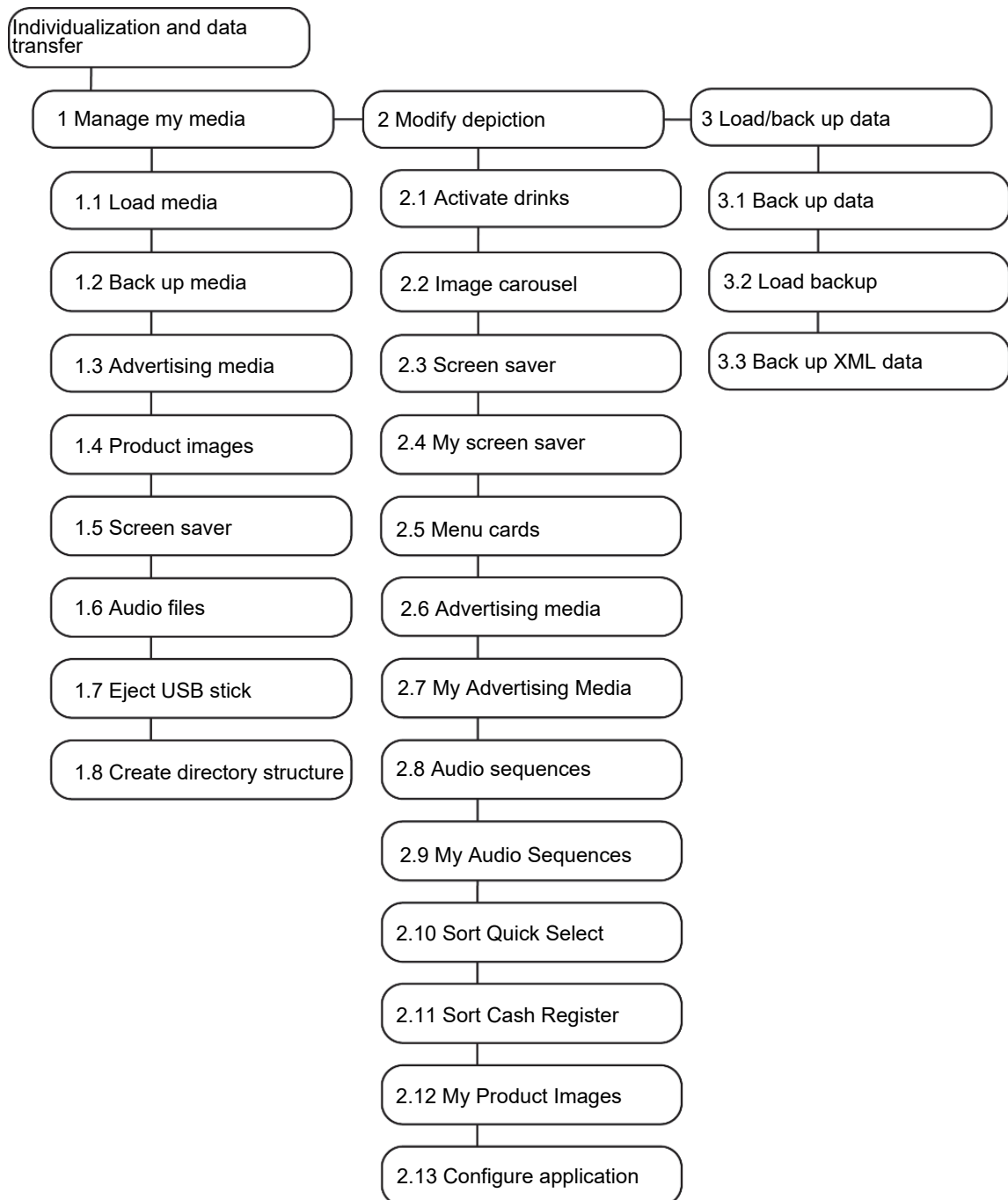



By using **4 Set default values**, selected parameters can be reset to the preset values.

5 Import FPC Becomes usable when a USB stick with a valid Franke product catalog is connected.

8 Eject USB stick Logs off connected USB sticks. If a USB stick is being used, the menu item will appear in green; otherwise it appears in orange.

The multimedia functions are only available in the *Inspire Me* [▶ 41] (if available) and *Quick Select* [▶ 40] operating modes.

Audio functionality is only available on the A1000.

11.3 Switching to the maintenance level

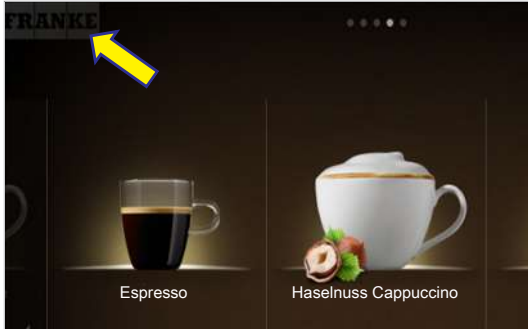

1. Tap the Franke logo.



2. Enter the PIN. *PIN codes* [▶ 51]

3. Press OK..

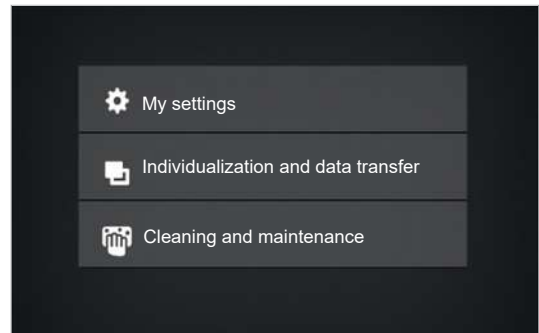

4. Select Menu.

11.4 Requirements for your own media

Media	Advertising im- ages (advertis- ing media)	Product im- ages	Screen saver	Audio files (A1000)	Video files (advertising media)
Size	800 x 600 px	430 x 274 px	800 x 600 px	-	Max. 800 x 600 px (4:3) or 800 x 450 px (16:9)
Data for- mats	24-bit PNG	24-bit PNG and 8-bit al- pha channel (if necessary)	24-bit PNG	MP3, bit rate: max. 128 kbps Sampling frequency: max. 44.1 kHz, 16 bit (stereo) Speaker connection: 3.5 mm rca jack	AVI (Codec H263, DivX/ Xvid, MPEG-4 Part 2) Bit rate: max. 200 kbps; image frequency: max. 25 fps

Media	Advertising im- ages (advertis- ing media)	Product im- ages	Screen saver	Audio files (A1000)	Video files (advertising media)
Storage lo- cation on the USB stick	Folder: <i>\QML- Files\rc\cus- tom\images</i>	Folder: <i>\QML-Files \rc\custom \drinks</i>	Folder: <i>\QML-Files \rc\custom \screen- savers</i>	Folder: <i>\QML-Files\rc \custom\audio</i>	Folder: <i>\QML-Files\rc \custom\images</i>

11.5 Loading or deleting your own media



The upload process is the same for all media.

Free space: 50 MB

The images on the USB stick must be present in the required folder structure, have the correct data format, and be of the correct size. See Requirements for your own media (without multimedia).

Desired action	Menu item	Information / instruction
Load media onto the ma- chine	1.1 Load media	<ul style="list-style-type: none"> - Insert a USB stick with the required directory structure - Select the media type from the drop-down menu: Advertising media/Product images/Screen savers/Audio files - Select the media using drag&drop - Press Save
Back up media from the machine	1.2 Back up media	<ul style="list-style-type: none"> - Insert a USB stick - Select the media type - Save individual media files or all of the media onto the USB stick
Delete media	1.3 Advertising media 1.4 Product images 1.5 Screen saver 1.6 Audio files (A1000)	<ul style="list-style-type: none"> - Open the desired menu - Select the media that is no longer required - Delete the media that is no longer required by pressing the Clear button - Drag a medium from the selection below to an existing medium above: <p>The existing medium is replaced</p>

11.6 Using your own advertising media

11.6.1 Configuring your own advertising media

Menu item 2.7 My advertising media



The activated advertising media can be switched on for each drink by selecting **My settings > 2 Set Drinks**.

Desired action	Menu item	Information / instruction
Use media	2.7 My Advertising Media	<ul style="list-style-type: none"> – Tap the medium that you wish to use in the lower section – Drag the medium to the top
Remove used media	2.7 My Advertising Media	<ul style="list-style-type: none"> – Tap a medium that you no longer wish to use in the upper section – Drag the medium to the bottom
View a selection	2.7 My Advertising Media	<ul style="list-style-type: none"> – Select Preview to check the selection
Activate advertising media	2.7 My Advertising Media	<ul style="list-style-type: none"> – Select Change to activate the advertising media

11.6.2 Assigning my product images



An image must be assigned to each available product.

The images can be activated by selecting the menu item **My settings > Set machine > Operating mode**.

Products to which no image has been assigned will be displayed without an image.

You can either use the Franke images or your own, but you cannot mix the two types with one another.

Desired action	Menu item	Information / instruction
Select an image	2.12 My Product Images	<ul style="list-style-type: none"> – Tap the image – Press Select image
Remove an image	2.12 My Product Images	<ul style="list-style-type: none"> – Tap the image – Press Remove image

11.7 Displaying languages and configuring nutritional values

Desired action	Menu item	Information / instruction
Switching languages	2.13 Configure application	<ul style="list-style-type: none"> – Activate language switching – Select languages to be displayed – Flags can be replaced with the FSTA
Set the waiting time for switching language	2.13 Configure application	<ul style="list-style-type: none"> – Set the Timeout until the system switches back to the default language
Display nutritional value information	2.13 Configure application	<ul style="list-style-type: none"> – Activate the display of nutritional value information

11.8 Loading/backing up data

11.8.1 Backing up data

Desired action	Menu item	Information / instruction
Export a configuration and media	3.1 Back up data	<ul style="list-style-type: none"> – Export configuration – Back up Franke media – Back up your own media – Eject USB stick

11.8.2 Loading data

Desired action	Menu item	Information / instruction
Export a configuration and media	3.2 Load backup	<ul style="list-style-type: none"> - Load saved data (configuration, Franke media, your own media) - Eject USB stick

11.8.3 Backing up XML data

Desired action	Menu item	Information / instruction
Back up XML data	3.3 Back up XML data	Export operating data such as maintenance data, error logs, or product and machine counters

11.9 Restoring default values

Desired action	Menu item	Information / instruction
Set default values	4 Set default values	Restore the default values in the selected areas

12 TROUBLESHOOTING

12.1 Error messages

When an error occurs, the machine displays an error message which provides instructions on how to rectify the issue.

Non-self-service mode

When the non-self-service mode is selected, an error is indicated via a highlighted symbol. Tap the symbol for further information.

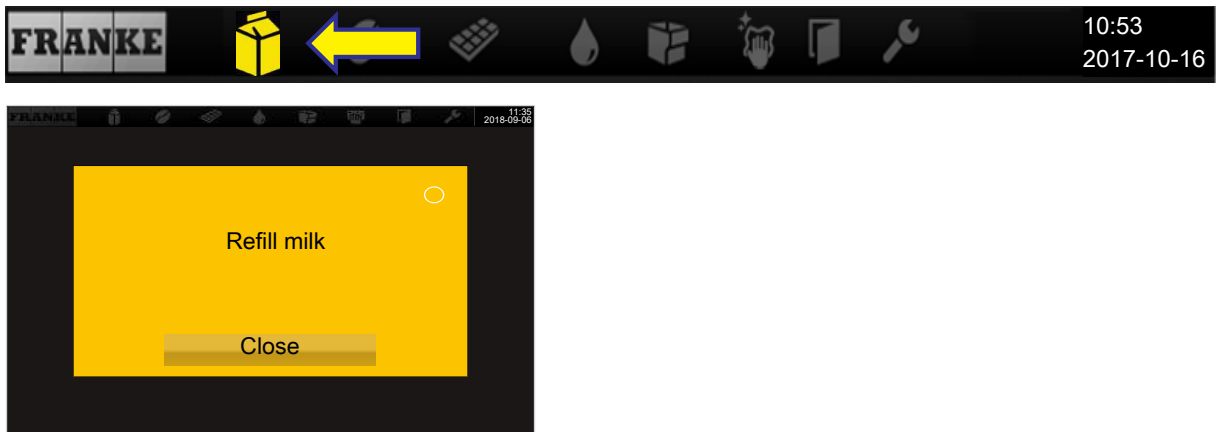

A message with instructions

Self-service operating mode





When the self-service mode is selected, an error is indicated via a colored triangle in the upper right-hand corner of the operator panel. Tap the symbol for further information.



If the entire system is affected by an error, error messages will appear automatically. The machine must be restarted in the event of serious errors.

- To restart the machine, switch it off via the main switch .
- Wait a minute and then switch it back on again.
- Check the power supply if the machine fails to start.
- Contact your service technician if the machine cannot be started or if you are unable to rectify the error.

12.1.1 Color code for error messages

	Temporary interruption
	System still fully functional
	System has limited functionality
	Some or all resources are locked

12.2 Tips for good coffee drinks



NOTICE

Poor drink quality

The oil from the coffee beans is deposited on the inside of the bean hopper as a thin film of oil. This deposited oil ages quickly and impairs the taste of the drinks produced.

- a) Remove the oil film from the inside of the bean hopper on a daily basis.
- b) To do this, use a dry cloth or a cloth moistened only with water.
- c) Do not use any cleaners, as these alter the taste of the coffee.



The aromas of the coffee beans evaporate in the bean hopper as a result of heat and air exchange. The quality will have already deteriorated after 3 hours.

- a) Coffee beans should not be moist.
- b) Seal any open coffee bean packs in an airtight manner.
- c) Do not store coffee beans in a refrigerator or freezer.
- d) Only fill the coffee beans into the bean hopper that you will need for the next 3 hours.

12.3 Help with problems concerning product quality

Problem	Possible causes	Possible solutions
Coffee tastes stale	Grind too coarse	Select a finer grind (see Setting the grind coarseness)
	Too little coffee	Increase the amount of coffee
	Temperature too low	Increase the temperature
	Coffee is old	Use fresh coffee
	Bean hopper not locked correctly	Check the bean hopper locking mechanism (see Emptying the bean hopper , Setting the grind coarseness)
Coffee tastes strange	Poor grind	Contact customer service
	Minimal coffee usage	Pour a small amount of coffee beans into the bean hopper
	Spoiled coffee beans	Replace coffee beans
	Residual cleaner	Rinse the machine
	Dirty cup	Check dishwasher
	Poor water quality (chlorine, hardness, etc.)	Have the water quality checked (see Water quality [▶ 30])
Coffee tastes bitter	Temperature too high	Lower coffee temperature
	Grind too fine	Select a coarser grind (see Emptying the bean hopper , Setting the grind coarseness)
	Coffee quantity too low	Increase the amount of coffee
	Roast too dark	Use lighter coffee roast
Coffee tastes sour	Temperature too low	Increase coffee temperature
	Roast too light	Use darker coffee roast
	Grind too coarse	Select a finer grind (see Emptying the bean hopper , Setting the grind coarseness)
Consistency of powder products	Viscous	Use less powder, use more water
	Watery	Use more powder, use less water
	Powder clumping or moist	Clean and dry powder system
Taste of powder products	Too sweet	Use less powder, use more water
	Not sweet enough	Use more powder, use less water
	Strange taste	Clean powder system

See also

 [Setting the grind coarseness](#) [[▶ 35](#)]

13 DECOMMISSIONING

13.1 Preparing for decommissioning

1. Clean the machine using the automatic cleaning function.
2. Empty the bean hopper and powder hopper.
3. Clean the bean hopper and powder hopper.
4. Clean the grounds container.
5. Empty the milk container.
6. Clean the milk container and container lid.
7. Clean the inside of the milk hose with a brush.
8. Clean the suction filter with a twisted-in-wire brush.

13.2 Short-term decommissioning (up to 3 weeks)

- ✓ The machine remains in place.
1. Clean the machine using the automatic cleaning function. *Cleaning [▶ 45]*
 2. Enable the energy-saving mode.
 3. Disconnect the machine from the power supply.
 4. Close the water supply if the machine has a mains water connection.
 5. Clean any add-on units.
 6. Switch off the add-on units and disconnect them from the power supply.

13.3 Long-term decommissioning



NOTICE

Functionality of the machine is impaired in the event of long-term decommissioning and storage

If you plan to start using your machine again at a later date, it is essential service measures are implemented. The coffee machine must be maintained, installed, and cleaned before preparing any drinks.

- a) Contact the Franke Service team for information regarding proper decommissioning and storage.
- b) Have your coffee machine drained by your service technician.
- c) Remedial maintenance may be required when commissioning the machine if it has been stored in excess of 6 months.

13.4 Transport and storage



Protect the machine from mechanical damage and adverse environmental conditions during transport and storage.

Protect the machine against the following:

- Vibrations
- Dust
- Sunlight
- Falling or tipping over
- Slipping during transport
- Frost in case the machine has not been drained and emptied completely

The following conditions must be fulfilled:

- Permissible temperatures if the machine is completely drained and emptied $-10 - 50\text{ °C}$
- Relative humidity: max. 80%
- Permanent and sufficient stability and fastening
- Machine in an upright position
- Machine empty and system drained
- Machine and loose parts packaged, preferably in their original packaging

13.5 Recommissioning after prolonged periods of storage or non-use



NOTICE

Deterioration in storage

Components may no longer function as they should if they have been stored or unused for periods in excess of 6 months.

- a) Contact your Service team for information regarding restoring and recommissioning your machine.

14 DISPOSAL OF PARTS

Disposal of consumable materials

- Observe the information on the label when disposing of any unused cleaning agent.
- Dispose of the fluids from the cleaning container or the drip tray in the wastewater system.

Disposing of the machine and other devices



The machine complies with European Directive 2012/19/EU regarding Waste Electrical and Electronic Equipment (WEEE) and must not be disposed of with household waste.



Dispose of electronic parts separately.



Dispose of plastic parts in accordance with their marking.



Two people are required for transporting the coffee machine.

15 TECHNICAL DATA

15.1 Capacities in accordance with DIN 18873-2:2016-02

Hourly capacity	Single preparation (cups per hour)	Double preparation (cups per hour)
Espresso	160	238
Coffee/Café crème	109	141
Hot water (200 ml)	164	-
Cappuccino	149	180
Latte macchiato	108	175
Milk Coffee	135	185
Hot chocolate	129	-

15.2 Technical data of the coffee machine







Weight	Approx. 58 kg
Bean hopper	Possible configurations: 1 x 2 kg, 2 x 1.2 kg, 2 x 0,6 kg, 1 x 2 kg + 1 x 0.6 kg, 2 x 1.2 kg + 1 x 0.6 kg or 2 x 0.6 kg + 1 x 0.6 kg, lockable
Powder hopper	One or two separate powder hoppers (for chocolate or milk powder), lockable
Brew boiler	Volume: 0,9 l Operating pressure: 800 kPa (8 bar) Power rating: Brühboiler-Leistung
Hot water boiler	Volume: 0,9 l Operating pressure: 800 kPa (8 bar) Power rating: Heisswasserboiler-Leistung
Steam boiler	Volume: 0,9 l Operating pressure: 250 kPa (2,5 bar) Power rating: Dampfboiler-Leistung
Wastewater tank (external)	16 l
Ambient conditions	Humidity: max. 80 % Ambient temperature: 5-32 °C
Noise emission	<70 dB(A)

15.3 Coffee machine electrical connections

Type	Voltage	Connection	Power	Fuse	Frequency
A800	200 V	2L PE	4500 W	30 A	50-60 Hz
(FCS4050)	200-220 V	2L PE	4500-5300 W	30 A	60 Hz
	200-220 V	3L PE	6800-8100 W	30 A	50-60 Hz
	200-240 V	3L PE	5590-7920 W	30 A	50-60 Hz
	220-240 V	1L N PE	2600-3000 W	13 A/15 A/16 A	50-60 Hz
	220-240 V	1L N PE	4400-5200 W	30 A	50-60 Hz

Type	Voltage	Connection	Power	Fuse	Frequency
	380 V	3 L N PE	6300 W	15 A/16 A	50 Hz
	380-415 V	3 L N PE	6300-7500 W	15 A/16 A	50-60 Hz
A800	400 V	3L PE	4,700 W	16 A	50 Hz
(FCS4050)	400 V	3L PE	6,650 W	16 A	50 Hz
Ship versions	440 V	3L PE	5,300 W		50 Hz
	440 V	3L PE	7,800 W		50 Hz

15.4 Power cord

Country	Item number	Connector
CN	560.0005.151	 10A
Taiwan	560.0006.625	 10A
Taiwan	560.0006.636	 10A
CH	560.0535.235	 10A
EU	560.0535.302	 10A
USA	560.0004.971	—
EU	560.0003.513	 16A
CH	560.0003.514	 16A
EU, CN	560.0004.939	—
Ship versions	560.0537.607	—
JP, EU	560.0000.160	—
EU	560.0003.575	—

INDEX

Numeric

5-step method 11, 46

A

Advertising media 67

Ambient conditions 76

B

Bean hopper 76

Boiler

Brew boiler 76

Hot water boiler 76

Steam boiler 76

C

Cancel button 11

Capacities 76, 000

Cleaning 47

Cleaning container

Disposal of fluid 75

Cleaning tablets 14

Coffee boiler 76

Coffee machine

Cleaning 47

Connection

electrical 76, 77

Credit Mode 26

D

Dashboard 11

Decommissioning 73

Detergents

Disposal 75

Dimensioned drawing 28

Dimensions 27

Disposal 75

Drip grid plate 15

Drip tray

Disposal of fluid 75

E

Electronic parts

Disposal 75

Error message

Color code 13

Depiction 13

Error messages 70

G

Grind coarseness 35

Grinder adjustment wrench 15

Grounds ejection 29

I

Intended use 6

M

Manual set 15

Measurements 27

Measuring cup 15

Media

Backing up 68

Loading 68, 69

Milk system cleaning agent

Dosing bottle 14

N

Noise emission 76

O

Operating mode

Cash Register 25

Operation mode

Non-self-service mode	70	Wipe protection	50
Quick Select	25		
Self-service	70		
P			
<hr/>			
Plastic parts			
Disposal	75		
Powder hopper	76		
Power connection	76, 77		
Product images	67		
R			
<hr/>			
Requirements	11		
S			
<hr/>			
Safety	7		
Screen			
Cleaning	50		
Wipe protection	50		
Screen saver	67		
Spout	40		
Start button	11		
Steam output	43		
Steam wand	43		
Symbols	11		
Dashboard	11		
Instructions	11		
Software	11		
T			
<hr/>			
Tips	11		
Transport	75		
Troubleshooting			
Machine error	70		
U			
<hr/>			
USB stick	15		
User manual	15		
W			
<hr/>			
Wastewater tank (external)	76		

MAKE IT
Wonderful!



Franke Kaffeemaschinen AG

Franke-Str. 9
CH-4663 Aarburg

Switzerland

Hotline-Phone: +41 62 787 37 37

Fax: +41 62 787 97 37

Internet www.franke.com

FRANKE